

# DYNA CYLINDERS

*Ultra-reliable, high-function  
tie-rod cylinder*

The DYNA cylinders, compact and lightweight mid-sized actuators compatible with ISO standards, offer a wide range of configurations and mounting types to meet various application requirements in a flexible manner. Moreover, the use of a new type of cushion needle and floating seal have made these products user-friendlier.

*Light  
&  
Compact*

## Product Line Up

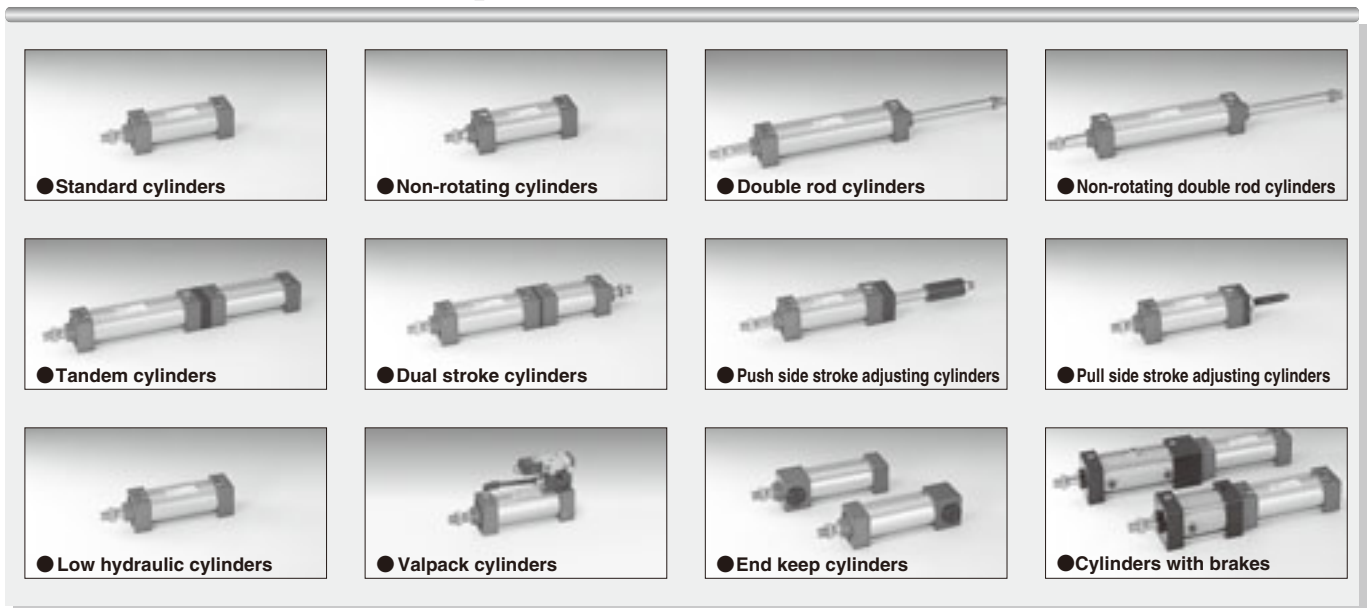

## Mounting type

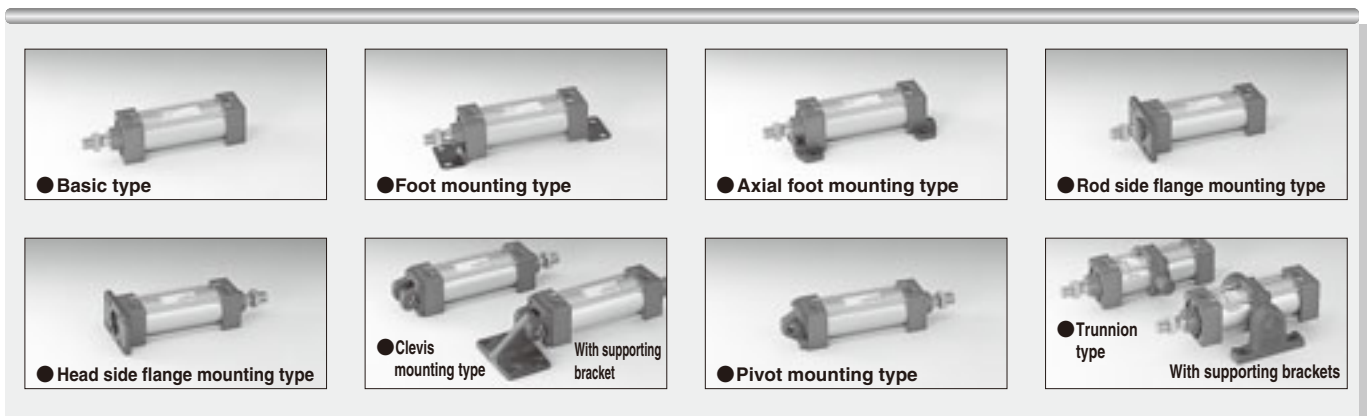

## Accessory



design in the smallest standard size for a mid-sized,

## 1 Extensive variation of functions

■ The series configuration together with its versatile functionality and specifications offers the best match for various mechanical devices.

## 2 Improved cushioning

■ Improved cushioning is gained by utilizing floating seal in the cushion section.

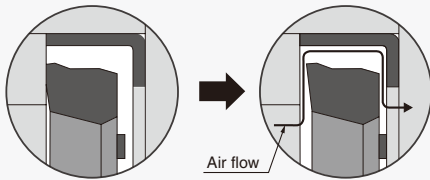

## 3 Long life

■ Oil impregnated sintered copper alloy in bushings enables stable operation and longer life.

## 4 New cushion needle

■ Using a new type of cushion needle that is completely embedded in the cylinder body offers fine adjustment for better performance.

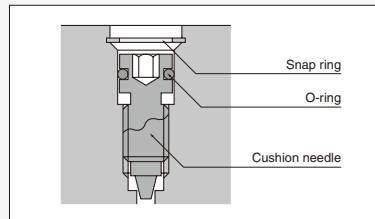

## 5 Safe self-locking mechanism

■ New release of cylinders with brakes. Exhausting compressed air pushes a brake shoe against the piston rod thereby stopping the cylinder.

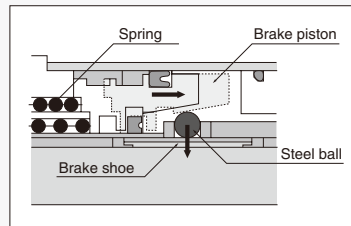

※ Steel balls and a brake shoe are secured in position. Operating the brake piston enables activation or release of the brake.

### Series configurations

	Basic type	Foot mounting type	Axial foot mounting type	Rod side flange mounting type	Head side flange mounting type	Clavis mounting type (with supporting bracket)	Pivot mounting type	Trunnion type (with supporting brackets)
Standard cylinder ( $\phi 32$ [1.260]~ $\phi 125$ [4.921])	●	●	●	●	●	●	●	●
Non-rotating cylinder ( $\phi 40$ [1.575]~ $\phi 100$ [3.940])	○	○	○	○	○	○	○	○
Double rod cylinder ( $\phi 32$ [1.260]~ $\phi 125$ [4.921])	●	●	●	●	●	●	●	●
Non-rotating double rod cylinder ( $\phi 40$ [1.575]~ $\phi 100$ [3.940])	○	○	○	○	○	○	○	○
Tandem cylinder ( $\phi 40$ [1.575]~ $\phi 100$ [3.940])	●	●	●	●	●	●	●	●
Dual stroke cylinder ( $\phi 40$ [1.575]~ $\phi 100$ [3.940])	○	○	○	○	○	○	○	○
Push side stroke adjusting cylinder ( $\phi 40$ [1.575]~ $\phi 100$ [3.940])	●	●	●	●	●	●	●	●
Pull side stroke adjusting cylinder ( $\phi 40$ [1.575]~ $\phi 100$ [3.940])	○	○	○	○	○	○	○	○
Low hydraulic cylinder ( $\phi 32$ [1.260]~ $\phi 100$ [3.940])	●	●	●	●	●	●	●	●
Valpack cylinder ( $\phi 40$ [1.575]~ $\phi 100$ [3.940])	○	○	○	○	○	○	○	○
End keep cylinder ( $\phi 40$ [1.575]~ $\phi 100$ [3.940])	●	●	●	●	●	●	●	●
Cylinder with brake ( $\phi 40$ [1.575]~ $\phi 100$ [3.940])	○	○	○	○	○	○	○	○

mm [in.]

# Handling Instructions and Precautions



## General precautions

### Media

1. Use air for the media. For the use of any other media, consult us.
2. Air used for the DYNA cylinder should be clean air that contains no deteriorated compressor oil, water, dust, etc. Install an air filter (filtration of a minimum 40 μm) near the cylinder or valve to remove collected liquid or dust. In addition, drain the air filter periodically.

### Piping

Always thoroughly blow off (use compressed air) the tubing before connecting it to the DYNA cylinder. Entering chips, sealing tape, rust, etc., generated during piping work could result in air leaks or other defective operation.

### Atmosphere

If using in locations subject to dripping water, dripping oil, etc., or to large amounts of dust, use a cover to protect the unit.

### Lubrication

This equipment can be used without lubrication. If lubrication is required, use Turbine Oil Class 1 (ISO VG32) or lithium soap-based grease No.2 or equivalent.



## Handling

### Assembly of mounting bracket

Use mounting screws which are supplied with the bracket to assemble the mounting bracket. Use an Allen wrench to tighten the mounting screws evenly. When 4 screws are used, tighten diagonally from each corner. The tightening torque is shown below.

### Assembly and disassembly

For disassembly, insert an Allen wrench to loosen the tie rod nut, and remove the cover.

For assembly, screw in the tie rod nut with the hexagon socket facing outward. Evenly tighten diagonally from each corner. The tightening torque is shown below.

#### <Tightening torque of mounting brackets and tie rod nuts>

Bore size mm [in.]	Tightening torque
32, 40, 50 [1.260, 1.575, 1.969]	4.81N·m [3.55ft·lbf]
63 [2.480]	12.0N·m [8.85ft·lbf]
80, 100 [3.150, 3.940]	24.0N·m [17.7ft·lbf]
125 [4.921]	42.2N·m [31.1ft·lbf]

#### ● Width across flats of hexagon socket mm [in.]

Bore size	Tie rod nut	Mounting bracket
32 [1.260]	6 [0.236]	4 [0.157]
40, 50 [1.575, 1.969]	6 [0.236]	4 [0.157]
63 [2.480]	8 [0.315]	5 [0.197]
80, 100 [3.150, 3.940]	10 [0.394]	6 [0.236]
125 [4.921]	12 [0.472]	8 [0.315]

#### ● φ 32 [1.260in.]

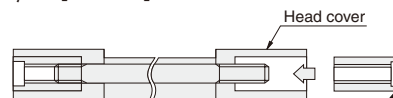

Use hexagon socket tie rod nuts on both sides for only 32φ

#### ● φ 40 [1.575in.]~ φ 125 [4.921in.]

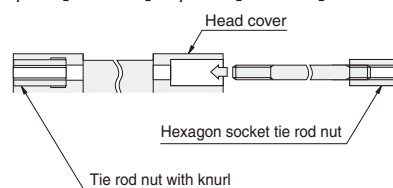

## Handling Instructions and Precautions



### Manual operation of end keep cylinder locking mechanism

While the locking mechanism is normally released automatically through cylinder operations, it can also be released manually. For manual release, insert an M4×0.7 screw that has 30mm [1.18in.] screw length into the manual override opening, thread it in about 3 turns into the internal lock piston, and then pull up the screw. To maintain the manual override for adjustment, etc., thread the locknut onto the screw and, with the locking mechanism in a released state, tighten the locknut against the cylinder.

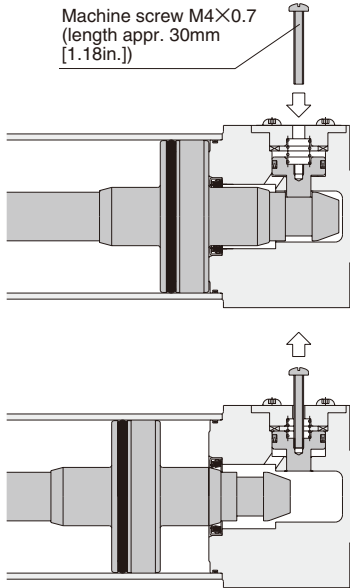

- Cautions:**
1. It is dangerous to release the lock when load (weight) is present on the piston rod, because it may cause the unintended piston rod's extension (or retraction). In this case, always supply air to the connection port opposite the one adjacent to the locking mechanism before releasing the locking mechanism.
  2. If the locking mechanism cannot easily be released even with manual override, it could be the result of galling of the lock piston and piston rod. In this case, supply air to the connection port opposite the one adjacent to the locking mechanism before releasing the locking mechanism.
  3. Because water, oil, dust, etc., intruding through the manual override opening may be a cause of defective locks or other erratic operation. If using in locations subject to dripping water, dripping oil, etc., or large amounts of dust, use a cover to protect the unit.
  4. If the circuit cannot maintain exhaust pressure at 0.03MPa [4.4psi.] or less due to using a manifold valve, use individual valve for operations.

### Dedicated muffler

The dedicated muffler can be mounted on the manual override opening.  
Dedicated muffler model SA-5 (mm)

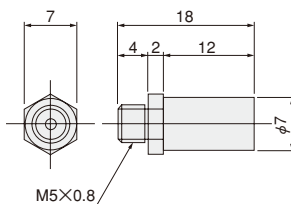

### Control circuit for the end keep cylinder

1. For control of the DYNA end keep cylinders, we recommend the use of 2-position, 4-, 5-port valves. Avoid the use of control circuit of ABR connections (exhaust centers) with 3-position valves that exhaust air from 2 ports.
2. Always use meter-out control for speed control. Meter-in control may result in failure of the locking mechanism to release.
3. Always set the air pressure to 0.15MPa [22psi.] or more.

- Cautions:**
1. It is dangerous to supply air to a connection port on a side with a locking mechanism while the cylinder has already been exhausted, because the piston rod may suddenly extend (or retract). In addition, since the lock piston could also cause galling of the lock piston and piston rod, resulting in defective operation. Always supply air to the connection port on the opposite side of the locking mechanism to ensure applying back pressure.
  2. When restarting operations after air has been exhausted from the cylinder due to completion of operations or to an emergency stop, always start by supplying air to a connection port on the opposite side of the locking mechanism.
  3. Connect the valve port A (NC) to the connection port on the side with the locking mechanism.

## Handling Instructions and Precautions



### Mounting and piping (for cylinder with brake)

#### Operating principle

The cylinder with brake uses a mechanism that consists of steel balls contacting an incline and it receives components of a spring force, then it transmits the force via a brake shoe to apply to the piston rod.

#### ● When the brake is released

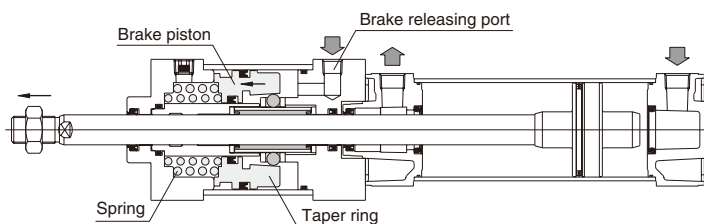

#### ● When the brake is applied

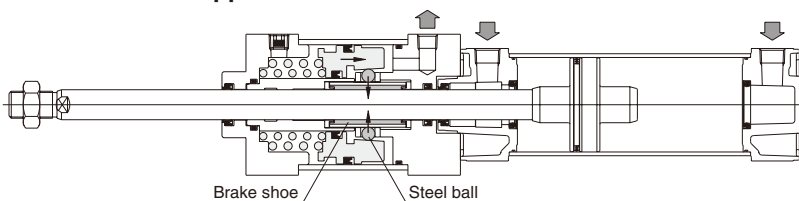

#### Precautions for installation

1. In the cylinder with brake, the brake piston in the single brake type is secured in place with 2 hexagon socket screws, and in the double brake type with 4 such screws, with the brake set in a released state at shipping.

When piping and installation is completed, or when performing operation checks, first supply at least 0.35MPa [51psi.] (0.4MPa [58psi.] for bore size of  $\phi 50$  [1.969in.]) of air to the brake release port, and remove the screws. Then exhausting the compressed air enables the piston rod to be held. While the unit could be operated with the screws removed, it is better for prevention of entering dust to use screws with nuts to secure it in place by inserting 2 or 3 thread ridges into the cylinder.

At this time, do not excessively tighten the screws as they could interfere with the brake piston, by re-locking it in place, or by constricting its movements.

2. Poor centering of the Cylinder with Brake may damage the seal or hasten wear on the brake shoe.

As poor centering could also result in inaccuracy of the stopping position, use of a cylinder joint is recommended.

#### When the brake is released

A supply of compressed air from the brake releasing port causes the brake piston including the taper ring, to retract thereby freeing the steel balls from the taper ring, which releases the brake and lets the piston rod freely slide.

#### When the brake is applied

Exhausting compressed air from the brake releasing port causes the spring to press against the brake piston, transmitting components of spring force via the taper ring to the steel balls, which then works via the brake shoe to transmit a perpendicular force to the piston rod and to apply friction force to the brake.

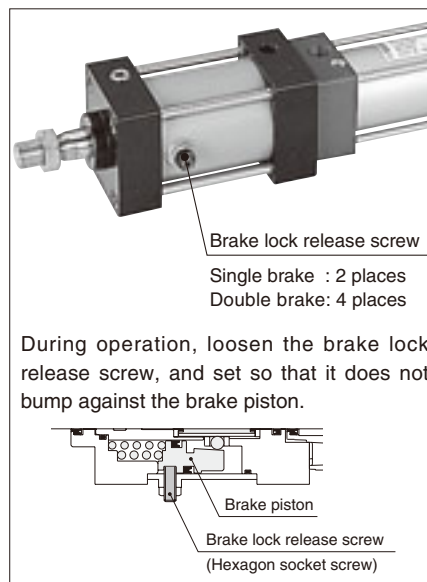



## Mounting and piping (for cylinder with brake)

### Control circuit

#### Electric control

When using a sequencer for control, the scanning time of the sequencer will affect the stopping position error. To improve the stopping position accuracy, use a TTL circuit, etc., to directly control the signal from the cylinder's sensor switch, and operate the valve.

#### Pneumatic circuit

1. To achieve a balance with the load, and a balance of differences in rod diameter area, always use a regulator with check valve.
2. For the cylinder control solenoid valve (V1), use a PAB connection 3-position solenoid valve, etc.
3. Install the solenoid valve for the brake (V2) as close to the cylinder as possible. Moreover, using a DC current solenoid valve will improve response (stopping position accuracy).

#### Example of basic circuit (Reference)

##### ● Horizontal mounting Spring lock

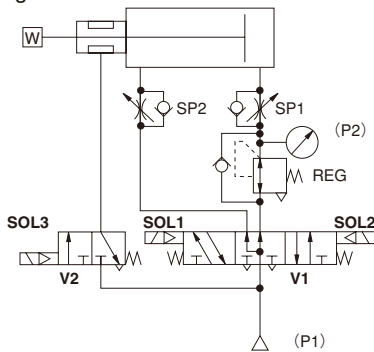

Regulator pressure setting

$$P2 = \frac{D^2 - d^2}{D^2} \cdot P1$$

D : Cylinder bore size (mm)  
d : Rod diameter (mm)  
P1 : Supply pressure (MPa)

Regulator pressure setting

$$P2' = \frac{D'^2 - d'^2}{D'^2} \cdot P1'$$

D' : Cylinder bore size [in.]  
d' : Rod diameter [in.]  
P1' : Supply pressure [psi.]

##### ● Vertical mounting Spring lock

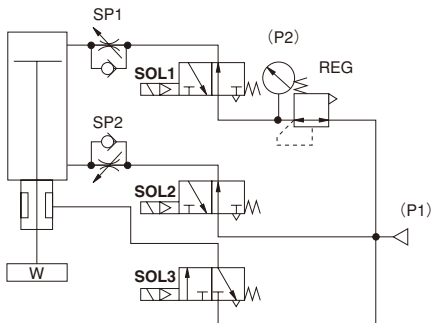

Regulator pressure setting

$$P2 = \frac{\pi (D^2 - d^2) P1 - 4W}{\pi \cdot D^2}$$

D : Cylinder bore size (mm)  
d : Rod diameter (mm)  
P1 : Supply pressure (MPa)  
W : Load (N)

Regulator pressure setting

$$P2' = \frac{\pi (D'^2 - d'^2) P1' - 4W'}{\pi \cdot D'^2}$$

D' : Cylinder bore size [in.]  
d' : Rod diameter [in.]  
P1' : Supply pressure [psi.]  
W' : Load [lbf]

##### ● Vertical mounting (push up)

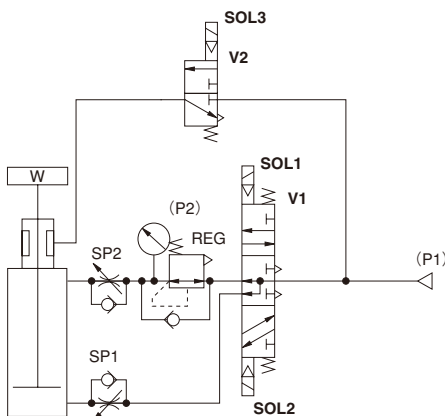

Regulator pressure setting

$$P2 = \frac{\pi \cdot D^2 \cdot P1 - 4W}{\pi (D^2 - d^2)}$$

D : Cylinder bore size (mm)  
d : Rod diameter (mm)  
P1 : Supply pressure (MPa)  
W : Load (N)

Regulator pressure setting

$$P2' = \frac{\pi \cdot D'^2 \cdot P1' - 4W'}{\pi (D'^2 - d'^2)}$$

D' : Cylinder bore size [in.]  
d' : Rod diameter [in.]  
P1' : Supply pressure [psi.]  
W' : Load [lbf]

ON, OFF switch sequence for solenoid (same for all mounting positions)

Valve	V1			V2
	SOL1	SOL2	SOL3	
Operating state	ON	OFF	OFF	OFF
Intermediate stop	OFF	OFF	OFF	OFF
Forward	OFF	ON	ON	ON
Reverse	ON	OFF	ON	ON

# Air Flow Rate and Air Consumption

While the air cylinder's air flow rate and air consumption can be found through the following calculations, the quick reference chart to the right provides the answers more conveniently.

$$\text{Air flow rate } Q_1 = \frac{\pi D^2}{4} \times L \times \frac{60}{t} \times \frac{P+0.1013}{0.1013} \times 10^{-6}$$

$$\text{Air consumption } Q_2 = \frac{\pi D^2}{4} \times L \times 2 \times n \times \frac{P+0.1013}{0.1013} \times 10^{-6}$$

- Q<sub>1</sub> : Required air flow rate for cylinder                    ℓ /min(ANR)
- Q<sub>2</sub> : Air consumption of cylinder                            ℓ /min(ANR)
- D : Cylinder tube inner diameter                            mm
- L : Cylinder stroke    mm
- t : Time required for cylinder to travel 1 stroke                    s
- n : Number of cylinder reciprocations per minute            times/min
- P : Pressure    MPa

$$\text{Air flow rate } Q_1' = \frac{\pi D'^2}{4} \times L' \times \frac{60}{t} \times \frac{P'+14.696}{14.696} \times \frac{1}{1728}$$

$$\text{Air consumption } Q_2' = \frac{\pi D'^2}{4} \times L' \times 2 \times n \times \frac{P'+14.696}{14.696} \times \frac{1}{1728}$$

- Q<sub>1</sub>' : Required air flow rate for cylinder                    ft.<sup>3</sup>/min.(ANR)\*
- Q<sub>2</sub>' : Air consumption of cylinder                            ft.<sup>3</sup>/min.(ANR)\*
- D' : Cylinder tube inner diameter                            in.
- L' : Cylinder stroke    in.
- t : Time required for cylinder to travel 1 stroke                    sec.
- n : Number of cylinder reciprocations per minute            times/min
- P' : Pressure    psi.

\* Refer to p.54 for an explanation of ANR.

Air consumption for each 1mm [0.0394in.] stroke      cm<sup>3</sup> [in.<sup>3</sup>]/Reciprocation (ANR)

Bore size mm [in.]	Air pressure MPa [psi.]								
	0.1 [15]	0.2 [29]	0.3 [44]	0.4 [58]	0.5 [73]	0.6 [87]	0.7 [102]	0.8 [116]	0.9 [131]
<b>32 [1.260]</b>	3.20 [0.1953]	4.78 [0.2917]	6.37 [0.3887]	7.96 [0.4858]	9.55 [0.5828]	11.14 [0.6798]	12.72 [0.7762]	14.31 [0.8733]	15.90 [0.9703]
<b>40 [1.575]</b>	4.99 [0.3045]	7.48 [0.4565]	9.96 [0.6078]	12.44 [0.7591]	14.92 [0.9105]	17.40 [1.0618]	19.88 [1.2132]	22.36 [1.3645]	24.84 [1.5158]
<b>50 [1.969]</b>	7.80 [0.4760]	11.68 [0.7128]	15.56 [0.9495]	19.43 [1.1857]	23.31 [1.4225]	27.19 [1.6592]	31.06 [1.8954]	34.93 [2.1316]	38.78 [2.3665]
<b>63 [2.480]</b>	12.39 [0.7561]	18.54 [1.1314]	24.70 [1.5073]	30.85 [1.8826]	37.01 [2.2585]	43.16 [2.6338]	49.32 [3.0097]	55.46 [3.3844]	61.57 [3.7572]
<b>80 [3.150]</b>	19.98 [1.2193]	29.90 [1.8246]	39.83 [2.4306]	49.75 [3.0359]	59.67 [3.6413]	69.60 [4.2473]	79.52 [4.8526]	89.45 [5.4586]	99.37 [6.0640]
<b>100 [3.940]</b>	31.21 [1.9046]	46.72 [2.8510]	62.23 [3.7975]	77.73 [4.7434]	93.24 [5.6899]	108.75 [6.6364]	124.25 [7.5822]	139.76 [8.5287]	155.27 [9.4752]
<b>125 [4.921]</b>	48.77 [2.9761]	73.00 [4.4548]	97.23 [5.9334]	121.46 [7.4120]	145.69 [8.8906]	169.92 [10.369]	194.14 [11.847]	218.37 [13.326]	242.60 [14.804]

The figures in the table show the air flow rate and air consumption when an air cylinder makes 1 reciprocation with stroke of 1mm [0.0394in.]. The air flow rate and consumption actually required is found by the following calculations.

- Finding the air flow rate (for selecting F.R.L., valves, etc.)  
Example: When operating an air cylinder with bore size of 40mm [1.575in.] at speed of 300mm/s [11.8in./sec.], and under air pressure of 0.5MPa [73psi.]

$$14.92 \times \frac{1}{2} \times 300 \times 10^{-3} = 2.24 \text{ ℓ / s [0.0791ft.<sup>3</sup>/sec.]} \text{ (ANR)}$$

(At this time, the air flow rate per minute is  $14.92 \times \frac{1}{2} \times 300 \times 60 \times 10^{-3} = 134.28 \text{ ℓ /min [4.74ft.<sup>3</sup>/min.]} \text{ (ANR).}$

- Finding the air consumption  
Example 1. When operating an air cylinder with bore size of 40mm [1.575in.] and stroke of 100mm [3.94in.], and under air pressure of 0.5MPa [73psi.], for 1 reciprocation

$$14.92 \times 100 \times 10^{-3} = 1.492 \text{ ℓ [0.0527ft.<sup>3</sup>$$

- Example 2. When operating an air cylinder with bore size of 40mm [1.575in.] and stroke of 100mm [3.94in.], and under air pressure of 0.5MPa [73psi.], for 10 reciprocations per minute

$$14.92 \times 100 \times 10 \times 10^{-3} = 14.92 \text{ ℓ /min [0.527ft.<sup>3</sup>/min.]} \text{ (ANR)}$$

# Cylinder Thrust

Select a suitable cylinder bore size considering the load and air pressure to obtain the required thrust.

Since the figures in the table are calculated values, select a bore size that results in a load ratio (load ratio =  $\frac{\text{Load}}{\text{Calculated value}}$ ) of 70% or less (50% or less for high speed application).

Bore size mm [in.]	Rod diameter mm [in.]	Operation	Pressure area mm <sup>2</sup> [in. <sup>2</sup> ]	Air pressure MPa [psi.]											N [lbf.]
				0.1 [15]	0.2 [29]	0.3 [44]	0.4 [58]	0.5 [73]	0.6 [87]	0.7 [102]	0.8 [116]	0.9 [131]	1 [145]		
<b>32 [1.260]</b>	<b>12 [0.472]</b>	Push side	804 [1.246]	80 [18.0]	161 [36.2]	241 [54.2]	322 [72.4]	402 [90.4]	482 [108]	563 [127]	643 [145]	724 [163]	804 [181]		
		Pull side	690 [1.070]	69 [15.5]	138 [31.0]	207 [46.5]	276 [62.0]	345 [77.6]	414 [93.1]	483 [109]	552 [124]	621 [140]	690 [155]		
<b>40 [1.575]</b>	<b>16 [0.630]</b>	Push side	1256 [1.947]	126 [28.3]	251 [56.4]	377 [84.7]	502 [113]	628 [141]	754 [169]	879 [198]	1005 [226]	1130 [254]	1256 [282]		
		Pull side	1055 [1.635]	106 [23.8]	211 [47.4]	317 [71.3]	422 [94.9]	528 [119]	633 [142]	739 [166]	844 [190]	950 [214]	1055 [237]		
<b>50 [1.969]</b>	<b>20 [0.787]</b>	Push side	1963 [3.043]	196 [44.1]	393 [88.3]	589 [132]	785 [176]	982 [221]	1178 [265]	1374 [309]	1570 [353]	1767 [397]	1963 [441]		
		Pull side	1649 [2.556]	165 [37.1]	330 [74.2]	495 [111]	660 [148]	825 [185]	989 [222]	1154 [259]	1319 [297]	1484 [334]	1649 [371]		
<b>63 [2.480]</b>	<b>20 [0.787]</b>	Push side	3117 [4.831]	312 [70.1]	623 [140]	935 [210]	1247 [280]	1559 [350]	1870 [420]	2182 [491]	2494 [561]	2805 [631]	3117 [701]		
		Pull side	2803 [4.345]	280 [62.9]	561 [126]	841 [189]	1121 [252]	1402 [315]	1682 [378]	1962 [380]	2242 [504]	2523 [567]	2803 [630]		
<b>80 [3.150]</b>	<b>25 [0.984]</b>	Push side	5026 [7.790]	503 [113]	1005 [226]	1508 [339]	2010 [452]	2513 [565]	3016 [678]	3518 [791]	4021 [904]	4523 [1017]	5026 [1130]		
		Pull side	4536 [7.031]	454 [102]	907 [204]	1361 [306]	1814 [408]	2268 [510]	2722 [612]	3175 [714]	3629 [816]	4082 [918]	4536 [1020]		
<b>100 [3.940]</b>	<b>30 [1.181]</b>	Push side	7853 [12.17]	785 [176]	1571 [353]	2356 [530]	3141 [706]	3927 [883]	4712 [1059]	5497 [1236]	6282 [1412]	7068 [1589]	7853 [1765]		
		Pull side	7147 [11.08]	715 [161]	1429 [321]	2144 [482]	2859 [643]	3574 [803]	4288 [964]	5003 [1125]	5718 [1285]	6432 [1446]	7147 [1607]		
<b>125 [4.921]</b>	<b>35 [1.378]</b>	Push side	12271 [19.02]	1227 [276]	2454 [552]	3681 [827]	4908 [1103]	6136 [1379]	7363 [1655]	8590 [1931]	9817 [2207]	11044 [2483]	12271 [2759]		
		Pull side	11310 [17.53]	1131 [254]	2262 [508]	3393 [763]	4524 [1017]	5655 [1251]	6786 [1525]	7917 [1780]	9048 [2034]	10179 [2288]	11310 [2542]		

# DYNA TANDEM CYLINDERS



## Symbol

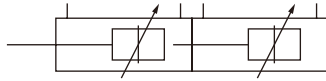

## Specifications

Item	Bore size mm [in.]	40 [1.575]	50 [1.969]	63 [2.480]	80 [3.150]	100 [3.940]
Operation type		Double acting type				
Media		Air				
Mounting type		Basic type, Foot type, Axial foot type, Rod side flange type, Head side flange type, Clevis type, Pivot type, Trunnion type				
Operating pressure range MPa [psi.]		0.05~0.7 [7~102]				
Proof pressure MPa [psi.]		1.05 [152]				
Operating temperature range °C [°F]		-10~70 [14~158] (Freezing prohibited, With sensor is 0~60 [32~140].)				
Operating speed range mm/s [in./sec.]		30~700 [1.2~27.6]				
Cushion		Variable cushion at both ends of stroke (applied to each cylinder)				
Cushion stroke mm [in.]		16 [0.630]	20 [0.787]			25 [0.984]
Lubrication		Not required (If lubrication is required, use Turbine Oil Class 1 (ISO VG32) or equivalent.)				
Port size	Rc	1/4	3/8			1/2

## Bore Size and Stroke

Stroke 2	Bore size	Stroke 1									Maximum available stroke (Stroke 1+Stroke 2)
		50	75	100	150	200	250	300	350	400	
Stroke 2	40	0, 25, 50, 100 150, 200, 250 300, 350, 400	0, 25, 75, 125 175, 225, 275 325	0, 50, 100, 150 200, 250, 300	0, 50, 100, 150 200	0, 50, 100	0	—	—	—	800
	50, 63	0, 25, 50, 100 150, 200, 250 300, 350, 400 450	0, 25, 75, 125 175, 225, 275 325, 375, 425	0, 50, 100, 150 200, 250, 300 350, 400	0, 50, 100, 150 200, 250, 300	0, 50, 100, 150 200	0, 50, 100	0	—	—	1000
	80, 100	0, 25, 50, 100 150, 200, 250 300, 350, 400 450, 550, 650	0, 25, 75, 125 175, 225, 275 325, 375, 425 525, 625	0, 50, 100, 150 200, 250, 300 350, 400, 500 600	0, 50, 100, 150 200, 250, 300 350, 450	0, 50, 100, 150 200, 250, 300 400	0, 50, 100 150, 200 250	0, 50, 100 150, 200	0, 50 100	0	1000

Caution: Figures in the table are a combination of stroke 2 (standard) corresponding to stroke 1 (standard). ● About stroke 1 and stroke 2

Remarks: 1. Stroke tolerance; Strokes of 250 or less:  $^{+1}_{0} [^{+0.039}_{0} \text{in.}]$   
Strokes of 251~1000:  $^{+1.5}_{0} [^{+0.059}_{0} \text{in.}]$

- For non-standard strokes, consult us.
- For the maximum available stroke with bellows specification, see p.538.

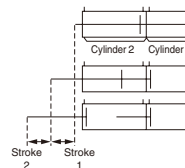

Stroke 1 is the stroke of cylinder 1.  
Stroke 2 is obtained by subtracting stroke 1 from the stroke of cylinder 2.

## Order Codes

**DDA** 63×100×50 — — — — — —

**Bore size**  
×  
**Stroke1**  
×  
**Stroke2**

**Types of bellows**  
JT — Nylon tarpaulin (~80°C [176°F])  
JC — Chloroprene (~100°C [212°F])  
JK — Conex (~200°C [392°F])  
JA — Alumix (~250°C [482°F])  
● Conex is a registered trademark of Teijin, Inc.  
● The temperatures shown are the bellows' own durable temperatures, and are not temperatures for cylinder use.

**Cylinder specification**  
T — Tandem cylinder  
JT — Tandem cylinder with bellows

**DYNA Cylinder Basic model**

**Mounting type**  
Blank — Basic type  
1 — Foot mounting type  
2 — Axial foot mounting type  
3 — Rod side flange mounting type  
5 — Head side flange mounting type  
7 — Clevis mounting type (with pin)  
7-7C — Clevis mounting type (with supporting bracket)  
8 — Pivot mounting type  
11 — Trunnion type  
11-11T — Trunnion type (with supporting brackets)  
● Mounting brackets are already assembled at shipping.  
● Orders for mounting brackets only are also accepted.

**Sensor switch (For cylinder with magnet)**  
ZC130 — 2-lead wire Solid state type with indicator lamp DC10~28V  
ZC153 — 3-lead wire Solid state type with indicator lamp DC4.5~230V  
CS5T — 2-lead wire Reed switch type without indicator lamp DC5~28V

AC85~115V  
DC3~30V  
DC10~28V  
AC85~230V  
DC10~30V  
DC10~30V

CS11T — 2-lead wire Reed switch type with indicator lamp  
CS2F — DIN type Reed switch type with indicator lamp  
CS3F — DIN type Reed switch type with indicator lamp  
CS4F — DIN type Reed switch type with indicator lamp  
CS5F — DIN type Reed switch type without indicator lamp

● For mounting location of sensor switch, see p.534.  
● CS□F comes with a DIN connector. All others are grommet type.  
● Orders for sensor switches only are also accepted.

**Rod end accessory**  
Blank — No rod end accessory  
Y — With Y type knuckle (with pin)  
I — With I type knuckle  
● For the cylinder joint and cylinder rod end, see p.1568.  
● Orders for rod end accessories only are also accepted.  
● For dimensions of rod end accessories, see p.537.

**Number of sensor switches**  
1 — With 1 sensor switch  
2 — With 2 sensor switches  
: :  
: :  
n — With n sensor switches

**Lead wire length (Applicable only to ZC, CS□T types)**  
A : 1000mm [39in.]  
B : 3000mm [118in.]



# Inner Construction and Major Parts

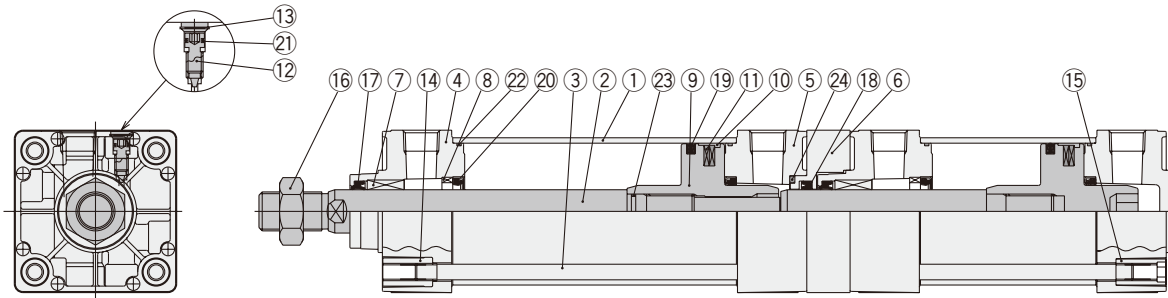

## ● Operation principle of tandem cylinders

Tandem Cylinders are a set of 2 cylinders joined end to end. It can be used as a 2-stage stroke cylinder by supplying air to either Port A or Port B. It can also obtain twice the thrust within the stroke 1 range.

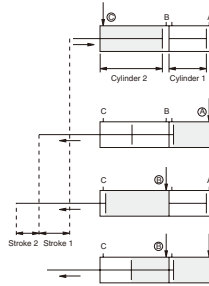

The rods retract strokes 2 and 1 when air is supplied from Port C.

The rod moves stroke 1 when air is supplied from Port A.

The rod moves stroke 2 when air is supplied from Port B.

Twice the thrust is obtained within the stroke 1 range when air is supplied from Ports A and B.

## Major Parts and Materials

No.	Parts	Materials
①	Cylinder tube	Aluminum alloy
②	Piston rod	Carbon steel for machine structural use
③	Tie rod	Carbon steel for machine structural use
④	Rod cover	Aluminum die-casting
⑤	Head cover	Aluminum die-casting
⑥	Spacer	Aluminum alloy
⑦	Rod bushing	Oil impregnated sintered copper alloy
⑧	Keep ring	Aluminum alloy
⑨	Piston	Aluminum alloy
⑩	Wear ring	Plastic
⑪	Magnet	Rubber magnet
⑫	Cushion needle	Carbon steel for machine structural use
⑬	Snap ring	Spring steel
⑭	Tie rod nut R	Rolled steel for general structural use
⑮	Tie rod nut H	Chrome-molybdenum steel
⑯	Rod end nut	Rolled steel for general structural use

No.	Parts	Materials
⑰	Rod seal A	Synthetic rubber (NBR)
⑱	Rod seal B	Synthetic rubber (NBR)
⑲	Piston seal	Synthetic rubber (NBR)
⑳	Cushion seal	Synthetic rubber (NBR)
㉑	Cushion gasket	Synthetic rubber (NBR)
㉒	Tube gasket	Synthetic rubber (NBR)
㉓	Piston gasket	Synthetic rubber (NBR)
㉔	Spacer gasket	Synthetic rubber (NBR)
—	Foot mounting bracket	Rolled steel for general structural use
—	Axial foot mounting bracket	Cast iron
—	Flange mounting bracket	Rolled steel for general structural use
—	Clevis mounting bracket	Cast iron
—	Clevis supporting bracket	Cast iron
—	Pivot mounting bracket	Cast iron
—	Trunnion bracket	Cast iron
—	Trunnion supporting bracket	Cast iron
—	Knuckles	Cast iron

## Seals

Parts	Rod seal A	Rod seal B	Piston seal	Cushion seal	Tube gasket	Cushion gasket	Piston gasket	Spacer gasket	
Bore size mm	Quantity	2★	1★	2	4	4★	4	1	1
40		DRP16	PNU16	PWP40N	CPF20	1.5×40	S5	S10	S25
50		DRP20	PNU20	PWP50N	CPF24	1.5×50	S6	S14	G30
63		DRP20	PNU20	PWP63N	CPF24	1.5×63	S6	S14	G30
80		DRP25	PNU25	PWP80N	CPF30	1.5×80	S6	S18	G35
100		DRP30	PNU30	PWP100N	CPF35	1.5×100	S6	S18	G40

Remark: Items marked with a star (★) are available as repair kits.  
Order codes: For tandem cylinders ... SRK-NDDAT [Bore size]

## Mass

Bore size mm [in.]	Zero stroke mass										Additional mass for each 1mm [0.0394in.] stroke		Mass of 1 sensor switch [w. holder]		Mass of knuckle	
	Basic type	Foot type	Axial foot type	Flange type	Clevis type (with pin)	Clevis type (w. supporting bkt.)	Pivot type	Trunnion type	Trunnion type (w. supporting bkt.)	Stroke1	Stroke2	ZC CS	T F	Y type knuckle (with pin)	I type knuckle	
										0.00300 [0.00662]	0.00300 [0.00662]					0.04 [0.09]
40 [1.575]	1.40 [3.09]	1.53 [3.37]	1.60 [3.53]	1.77 [3.90]	1.67 [3.68]	2.37 [5.23]	1.58 [3.48]	1.88 [4.15]	2.38 [5.25]	0.00428 [0.00944]	0.00428 [0.00944]	0.04 [0.09]	0.06 [0.13]	0.27 [0.60]	0.16 [0.35]	
50 [1.969]	2.20 [4.85]	2.37 [5.23]	2.52 [5.56]	2.59 [5.71]	2.59 [5.71]	3.29 [7.25]	2.46 [5.42]	2.75 [6.06]	3.25 [7.17]	0.00515 [0.01136]	0.00515 [0.01136]			0.04 [0.09]	0.06 [0.13]	0.34 [0.75]
63 [2.480]	2.97 [6.55]	3.20 [7.06]	3.49 [7.70]	3.50 [7.72]	3.45 [7.61]	4.15 [9.15]	3.39 [7.47]	3.67 [8.09]	4.17 [9.19]	0.00834 [0.01839]	0.00834 [0.01839]	0.04 [0.09]	0.06 [0.13]			0.34 [0.75]
80 [3.150]	5.15 [11.36]	5.53 [12.19]	6.00 [13.23]	6.75 [14.88]	6.07 [13.38]	6.79 [14.97]	6.23 [13.74]	6.31 [13.91]	7.03 [15.50]	0.01061 [0.02340]	0.01061 [0.02340]			0.04 [0.09]	0.06 [0.13]	0.87 [1.92]
100 [3.940]	6.61 [14.58]	7.08 [15.61]	7.89 [17.40]	8.83 [19.47]	7.85 [17.31]	8.57 [18.90]	8.00 [17.64]	8.14 [17.95]	8.86 [19.54]							1.47 [3.24]

Note: For lead wire length A (1000mm [39in.]).

Calculation example: For foot mounting type with bore size of 50mm, stroke1 of 100mm and stroke 2 of 50mm, 2.37+(0.00428×100)+(0.00428×50)=3.012kg [6.641lb.]

# Dimensions of Basic Type (mm)

DDAT  ×  ×

 DDAT

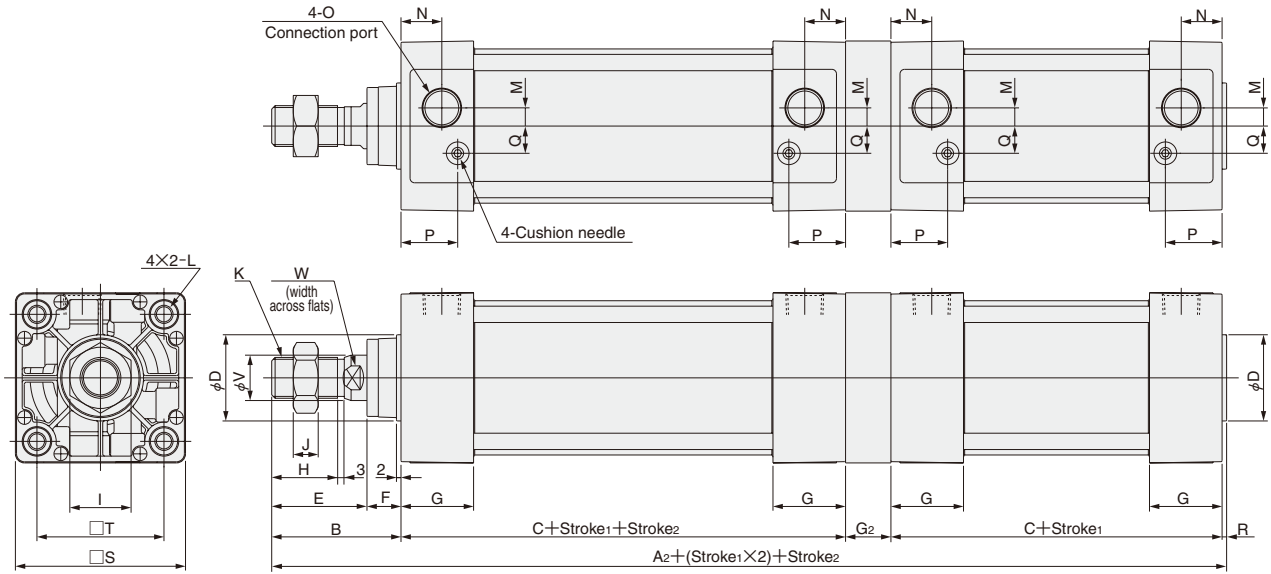

Code	A <sub>2</sub>	B	C	D	E	F	G	G <sub>2</sub>	H	I	J	K
40 [1.575]	257	49	93	32	34	15	31	20	21	22	8	M14×1.5
50 [1.969]	265	57	93	38	42	15	31	20	29	27	11	M18×1.5
63 [2.480]	271	57	96	38	42	15	32	20	29	27	11	M18×1.5
80 [3.150]	318	75	108	44	54	21	36	25	37	32	13	M22×1.5
100 [3.940]	318	75	108	50	54	21	36	25	37	36	14	M26×1.5

Code	L	M	N	O	P	Q	R	S	T	V	W
40 [1.575]	M 6×1 Depth 14	4	18	Rc1/4	25.5	10	2	50	37	16	14
50 [1.969]	M 6×1 Depth 14	7	18	Rc3/8	24	12	2	62	47	20	17
63 [2.480]	M 8×1.25 Depth 14	8	18	Rc3/8	25	12	2	75	56	20	17
80 [3.150]	M10×1.5 Depth 15	11	20	Rc1/2	29	16	2	94	70	25	21
100 [3.940]	M10×1.5 Depth 15	12	20	Rc1/2	29	18	2	112	84	30	26

DYNA CYLINDERS

## Dimensions of Foot Mounting Type (mm)

DDAT Bore size × Stroke1 × Stroke2 -1

CAD Foot mounting bracket only  
DDA Bore size -1

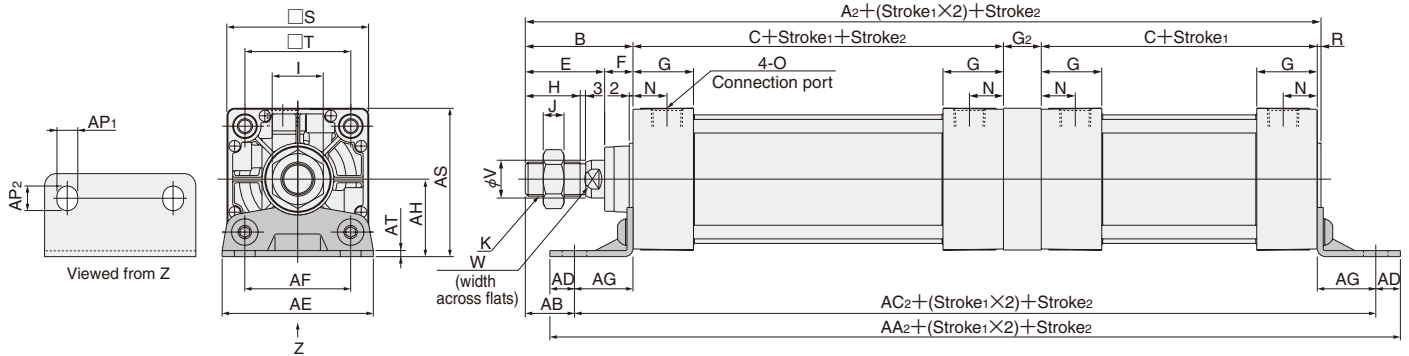

Bore mm [in.]	Code	A <sub>2</sub>	B	C	E	F	G	G <sub>2</sub>	H	I	J	K	N	O	R	S	T	V	W
40	[1.575]	257	49	93	34	15	31	20	21	22	8	M14×1.5	18	Rc1/4	2	50	37	16	14
50	[1.969]	265	57	93	42	15	31	20	29	27	11	M18×1.5	18	Rc3/8	2	62	47	20	17
63	[2.480]	271	57	96	42	15	32	20	29	27	11	M18×1.5	18	Rc3/8	2	75	56	20	17
80	[3.150]	318	75	108	54	21	36	25	37	32	13	M22×1.5	20	Rc1/2	2	94	70	25	21
100	[3.940]	318	75	108	54	21	36	25	37	36	14	M26×1.5	20	Rc1/2	2	112	84	30	26

Bore mm [in.]	Code	AA <sub>2</sub>	AB	AC <sub>2</sub>	AD	AE	AF	AG	AH	AP <sub>1</sub>	AP <sub>2</sub>	AS	AT
40	[1.575]	278	25.5	253	12.5	57	36	23.5	30	11	13	55	3.2
50	[1.969]	286	29	262	12	68	47	28	36.5	11	13	67.5	3.2
63	[2.480]	300	26	274	13	80	56	31	41	11	13	78.5	3.2
80	[3.150]	333	45	301	16	97	70	30	49	14	16	96	4
100	[3.940]	333	45	301	16	112	84	30	57	14	16	113	4

## Dimensions of Axial Foot Mounting Type (mm)

DDAT Bore size × Stroke1 × Stroke2 -2

CAD Axial foot mounting bracket only  
DDA Bore size -2

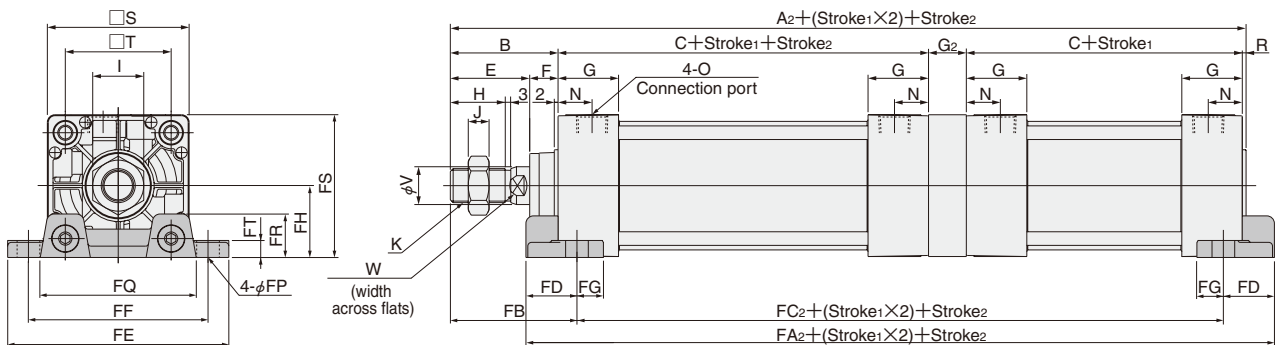

Bore mm [in.]	Code	A <sub>2</sub>	B	C	E	F	G	G <sub>2</sub>	H	I	J	K	N	O	R	S	T	V	W
40	[1.575]	257	49	93	34	15	31	20	21	22	8	M14×1.5	18	Rc1/4	2	50	37	16	14
50	[1.969]	265	57	93	42	15	31	20	29	27	11	M18×1.5	18	Rc3/8	2	62	47	20	17
63	[2.480]	271	57	96	42	15	32	20	29	27	11	M18×1.5	18	Rc3/8	2	75	56	20	17
80	[3.150]	318	75	108	54	21	36	25	37	32	13	M22×1.5	20	Rc1/2	2	94	70	25	21
100	[3.940]	318	75	108	54	21	36	25	37	36	14	M26×1.5	20	Rc1/2	2	112	84	30	26

Bore mm [in.]	Code	FA <sub>2</sub>	FB	FC <sub>2</sub>	FD	FE	FF	FG	FH	FP	FQ	FR	FS	FT
40	[1.575]	232	59	186	23	92	70	14	25	12	58	16	50	8
50	[1.969]	236	67	186	25	105	83	14	31	12	68	17	62	9
63	[2.480]	246	67	192	27	117	95	14	38	12	84	22	75.5	9
80	[3.150]	283	88	215	34	147	121	18	47	14	104	28	94	13
100	[3.940]	291	88	215	38	168	140	18	57	14	120	30	113	14

## Dimensions of Rod Side Flange Mounting Type (mm)

DDAT  ×  ×  -3

 Flange mounting bracket only  
DDA  -3

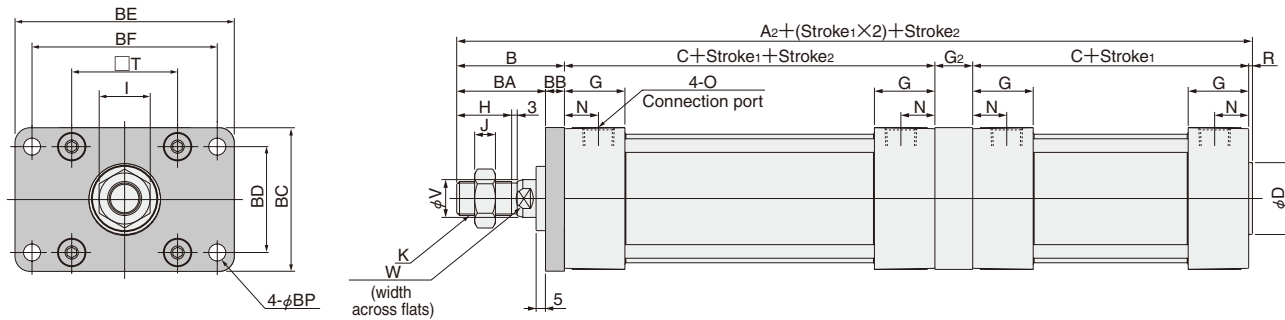

Code	A <sub>2</sub>	B	C	D	G	G <sub>2</sub>	H	I	J	K	N	O	R	T	V	W
40 [1.575]	257	49	93	32	31	20	21	22	8	M14×1.5	18	Rc1/4	2	37	16	14
50 [1.969]	265	57	93	38	31	20	29	27	11	M18×1.5	18	Rc3/8	2	47	20	17
63 [2.480]	271	57	96	38	32	20	29	27	11	M18×1.5	18	Rc3/8	2	56	20	17
80 [3.150]	318	75	108	44	36	25	37	32	13	M22×1.5	20	Rc1/2	2	70	25	21
100 [3.940]	318	75	108	50	36	25	37	36	14	M26×1.5	20	Rc1/2	2	84	30	26

Code	BA	BB	BC	BD	BE	BF	BP
40 [1.575]	39	10	52	36	84	70	7
50 [1.969]	47	10	65	47	104	86	9
63 [2.480]	47	10	76	56	116	98	9
80 [3.150]	59	16	95	70	143	119	12
100 [3.940]	59	16	115	84	162	138	12

## Dimensions of Head Side Flange Mounting Type (mm)

DDAT  ×  ×  -5

 Flange mounting bracket only  
DDA  -3

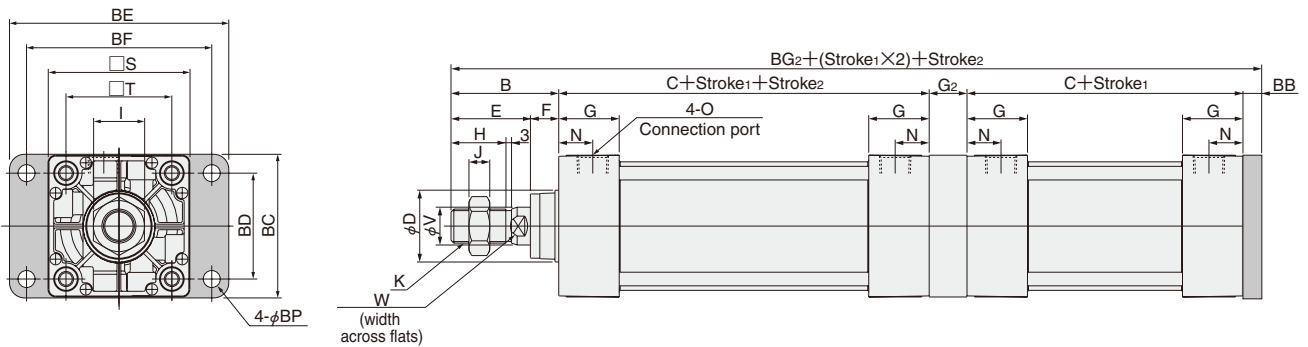

Code	B	C	D	E	F	G	G <sub>2</sub>	H	I	J	K	N	O	S	T	V	W
40 [1.575]	49	93	32	34	15	31	20	21	22	8	M14×1.5	18	Rc1/4	50	37	16	14
50 [1.969]	57	93	38	42	15	31	20	29	27	11	M18×1.5	18	Rc3/8	62	47	20	17
63 [2.480]	57	96	38	42	15	32	20	29	27	11	M18×1.5	18	Rc3/8	75	56	20	17
80 [3.150]	75	108	44	54	21	36	25	37	32	13	M22×1.5	20	Rc1/2	94	70	25	21
100 [3.940]	75	108	50	54	21	36	25	37	36	14	M26×1.5	20	Rc1/2	112	84	30	26

Code	BB	BC	BD	BE	BF	BG <sub>2</sub>	BP
40 [1.575]	10	52	36	84	70	265	7
50 [1.969]	10	65	47	104	86	273	9
63 [2.480]	10	76	56	116	98	279	9
80 [3.150]	16	95	70	143	119	332	12
100 [3.940]	16	115	84	162	138	332	12

# Dimensions of Clevis Mounting Type (mm)

DDAT  ×  ×  -7

 Clevis mounting bracket only  
DDA  -7

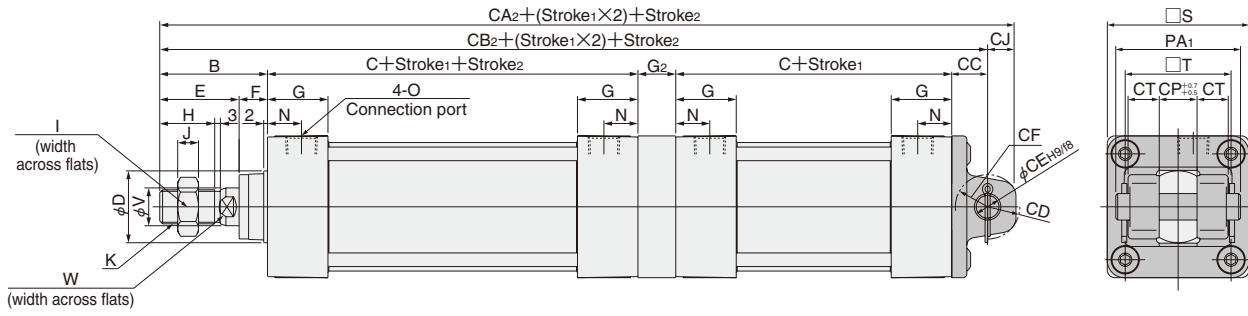

Code	B	C	D	E	F	G	G <sub>2</sub>	H	I	J	K	N	O	S	T	V	W
40 [1.575]	49	93	32	34	15	31	20	21	22	8	M14×1.5	18	Rc1/4	50	37	16	14
50 [1.969]	57	93	38	42	15	31	20	29	27	11	M18×1.5	18	Rc3/8	62	47	20	17
63 [2.480]	57	96	38	42	15	32	20	29	27	11	M18×1.5	18	Rc3/8	75	56	20	17
80 [3.150]	75	108	44	54	21	36	25	37	32	13	M22×1.5	20	Rc1/2	94	70	25	21
100 [3.940]	75	108	50	54	21	36	25	37	36	14	M26×1.5	20	Rc1/2	112	84	30	26

Code	CA <sub>2</sub>	CB <sub>2</sub>	CC	CD	CE	CF	CJ	CP	CT	PA <sub>1</sub>
40 [1.575]	287	274	19	R15	14	R17	13	20	12.5	58
50 [1.969]	297	282	19	R17	14	R17	15	20	16.5	66
63 [2.480]	303	288	19	R17	14	R17	15	20	16.5	66
80 [3.150]	369	348	32	R24	20	R30	21	32	17.5	78
100 [3.940]	369	348	32	R24	20	R30	21	32	17.5	78

● With Supporting Bracket DDAT  ×  ×  -7-7C

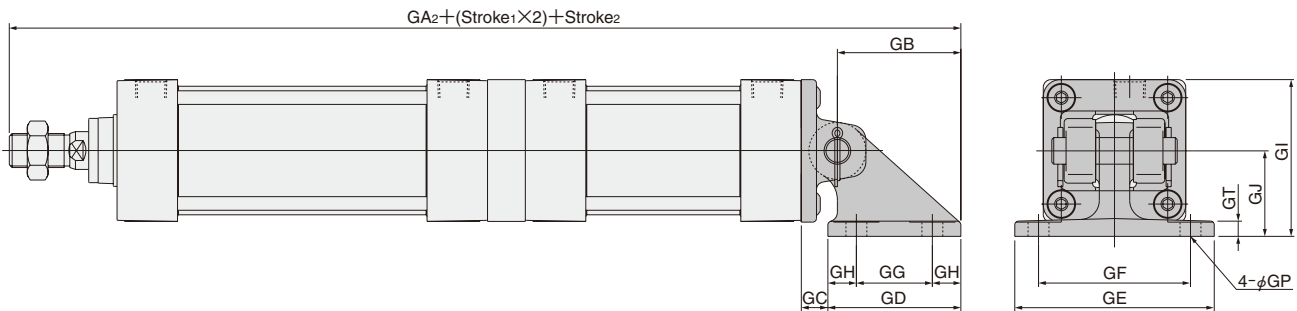

Code	GA <sub>2</sub>	GB	GC	GD	GE	GF	GG	GH	GI	GJ	GP	GT
40 [1.575]	340.5	66.5	12.5	73	105	80	40	16.5	70	45	11(Thru hole)	8
50 [1.969]	348.5	66.5	12.5	73	105	80	40	16.5	76	45	11(Thru hole)	8
63 [2.480]	354.5	66.5	12.5	73	105	80	40	16.5	82.5	45	11(Thru hole)	8
80 [3.150]	434.5	86.5	20.5	98	135	105	65	16.5	107	60	14(Thru hole)	12
100 [3.940]	434.5	86.5	20.5	98	135	105	65	16.5	116	60	14(Thru hole)	12

# Dimensions of Pivot Mounting Type (mm)

DDAT  ×  ×  -8

 Pivot mounting bracket only  
DDA  -8

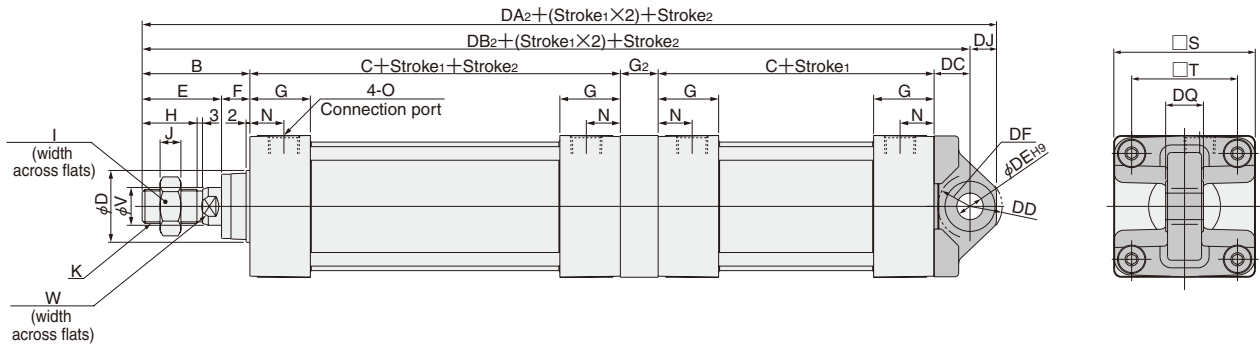

Code	B	C	D	E	F	G	G <sub>2</sub>	H	I	J	K	N	O	S	T	V	W
40 [1.575]	49	93	32	34	15	31	20	21	22	8	M14×1.5	18	Rc1/4	50	37	16	14
50 [1.969]	57	93	38	42	15	31	20	29	27	11	M18×1.5	18	Rc3/8	62	47	20	17
63 [2.480]	57	96	38	42	15	32	20	29	27	11	M18×1.5	18	Rc3/8	75	56	20	17
80 [3.150]	75	108	44	54	21	36	25	37	32	13	M22×1.5	20	Rc1/2	94	70	25	21
100 [3.940]	75	108	50	54	21	36	25	37	36	14	M26×1.5	20	Rc1/2	112	84	30	26

Code	DA <sub>2</sub>	DB <sub>2</sub>	DC	DD	DE	DF	DJ	DQ
40 [1.575]	288	274	19	R17	14	R17	14	20 <sup>0</sup> <sub>-0.084</sub>
50 [1.969]	296	282	19	R17	14	R17	14	20 <sup>0</sup> <sub>-0.084</sub>
63 [2.480]	302	288	19	R17	14	R17	14	20 <sup>0</sup> <sub>-0.084</sub>
80 [3.150]	369	348	32	R24	20	R25	21	32 <sup>0</sup> <sub>-0.100</sub>
100 [3.940]	368	348	32	R24	20	R26	20	32 <sup>0</sup> <sub>-0.100</sub>

DYNA CYLINDERS

# Dimensions of Trunnion Type (mm)

DDAT  ×  ×  -11

 Trunnion bracket only  
DDA  -11

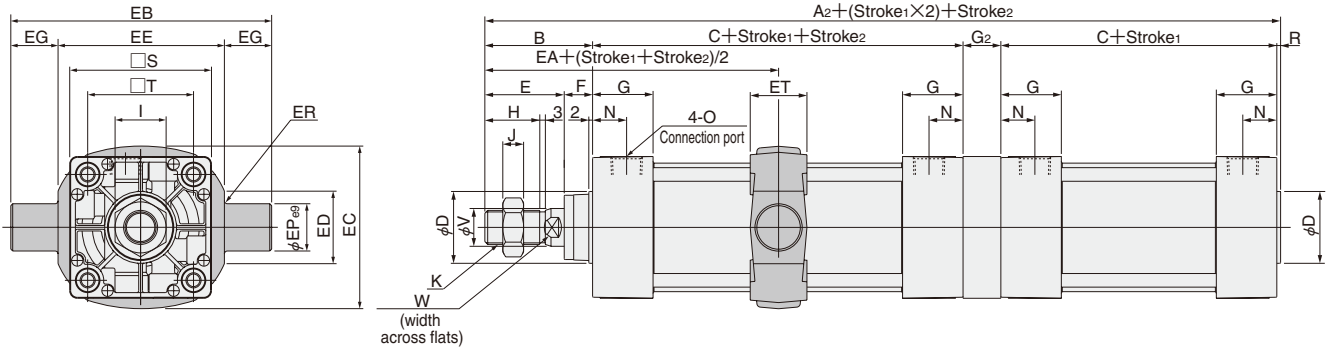

Bore mm [in.]	Code	A <sub>2</sub>	B	C	D	E	F	G	G <sub>2</sub>	H	I	J	K	N	O	R	S	T	V	W
	40 [1.575]	257	49	93	32	34	15	31	20	21	22	8	M14×1.5	18	Rc1/4	2	50	37	16	14
	50 [1.969]	265	57	93	38	42	15	31	20	29	27	11	M18×1.5	18	Rc3/8	2	62	47	20	17
	63 [2.480]	271	57	96	38	42	15	32	20	29	27	11	M18×1.5	18	Rc3/8	2	75	56	20	17
	80 [3.150]	318	75	108	44	54	21	36	25	37	32	13	M22×1.5	20	Rc1/2	2	94	70	25	21
	100 [3.940]	318	75	108	50	54	21	36	25	37	36	14	M26×1.5	20	Rc1/2	2	112	84	30	26

Bore mm [in.]	Code	EA	EB	EC	ED	EE	EG	EP	ER	ET
	40 [1.575]	95.5	113	60	30	63	25	25	R1.6	30
	50 [1.969]	103.5	126	72	30	76	25	25	R1.6	30
	63 [2.480]	105	138	87	40	88	25	25	R1.6	30
	80 [3.150]	129	164	105	40	114	25	25	R1.6	35
	100 [3.940]	129	182	129	44	132	25	25	R2	40

● With Supporting Brackets DDAT  ×  ×  -11-11T

 Trunnion supporting bracket only  
DDA  -11T

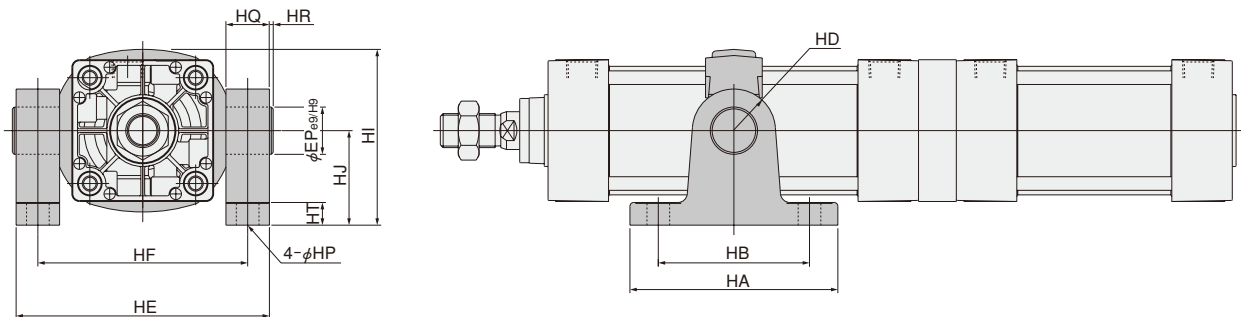

Bore mm [in.]	Code	HA	HB	HD	HE	HF	HI	HJ	HP	HQ	HR	HT	EP
	40 [1.575]	111	80	R22	109	86	80	50	12(Thru hole)	23	2	14	25
	50 [1.969]	111	80	R22	122	99	86	50	12(Thru hole)	23	2	14	25
	63 [2.480]	111	80	R22	134	111	93.5	50	12(Thru hole)	23	2	14	25
	80 [3.150]	121	85	R22	160	137	122.5	70	14(Thru hole)	23	2	14	25
	100 [3.940]	121	85	R22	178	155	134.5	70	14(Thru hole)	23	2	14	25

# SENSOR SWITCHES

## Symbol

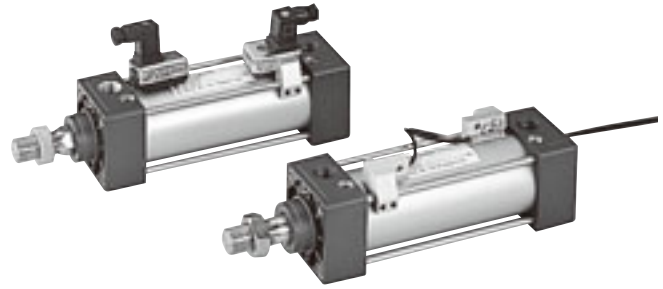
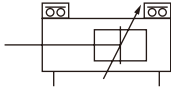

DYNA CYLINDERS

## Order Codes

● Without mounting holder — **ZC130** **A**

● With mounting holder — **ZC130** **A** — **NDDA** **40**

- Sensor switch model**
- ZC130** — 2-lead wire Solid state type with indicator lamp  
DC10~28V
  - ZC153** — 3-lead wire Solid state type with indicator lamp  
DC4.5~28V
  - CS5T** — 2-lead wire Reed switch type without indicator lamp  
DC5~28V, AC85~115V
  - CS11T** — 2-lead wire Reed switch type with indicator lamp  
DC10~28V
  - CS2F** — DIN connector Reed switch type with indicator lamp  
AC85~230V
  - CS3F** — DIN connector Reed switch type with indicator lamp  
DC10~30V
  - CS4F** — DIN connector Reed switch type with indicator lamp  
DC10~30V
  - CS5F** — DIN connector Reed switch type without indicator lamp  
DC3~30V

**NDDA**: Applicable to other than **CS□F**  
**NDF**: Applicable to **CS□F** only

**Lead wire length**  
(Applicable to other than **CS□F** only)  
**A** — 1000mm [39in.]  
**B** — 3000mm [118in.]

Bore size

● Order codes for mounting holders only

**C1** — **NDDA** **40**

**NDDA**: Applicable to other than **CS□F**  
**Blank**: For **CS□F**

**Sensor type**  
**C1**: Solid state type  
for **ZC1□□**  
Reed switch type  
for **CS□T**  
**DF**: Reed switch type  
for **CS□F**

Bore size

- 32** — For  $\phi$  32 [1.260in.]
- 40** — For  $\phi$  40 [1.575in.]
- 50** — For  $\phi$  50 [1.969in.]
- 63** — For  $\phi$  63 [2.480in.]
- 80** — For  $\phi$  80 [3.150in.]
- 100** — For  $\phi$  100 [3.940in.]
- 125** — For  $\phi$  125 [4.921in.]

● For details of sensor switches, see p.1544.

## Sensor Switches and Mounting Holders

● DYNA cylinder sensor switches come in 2 types, and 2 corresponding types of mounting holders are available. See the following for details.

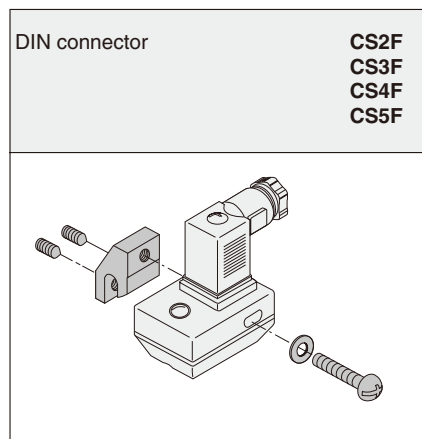
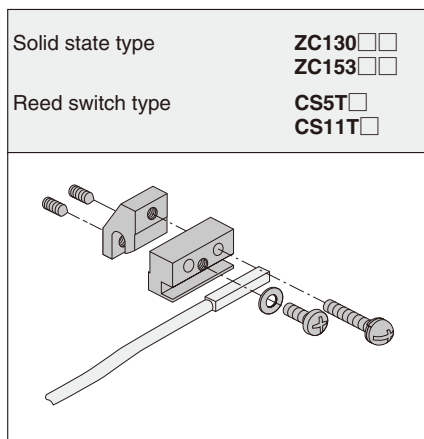



# Minimum Cylinder Strokes When Using Sensor Switches

mm

Sensor switch model	Bore size mm [in.]	2pcs. mounting				1pc. mounting	
		Mounting 2 pcs. on a tie rod		Mounting 1 pc. on each tie rod		Rod side	Head side
		In a straight line	In staggered positions	1-plane mounting	2-plane mounting		
Solid state type	ZC130 ZC153	32 [1.260]	55 (90)	15 (90)	48 (90)	15 (90)	15 (66)
		40 [1.575]	55 (90)	15 (90)	48 (90)	15 (90)	15 (66)
		50 [1.969]	55 (90)	15 (90)	15 (90)	15 (90)	15 (66)
		63 [2.480]	58 (93)	15 (93)	15 (93)	15 (93)	15 (63)
		80 [3.150]	58 (99)	15 (99)	15 (99)	15 (99)	15 (69)
		100 [3.940]	58 (99)	15 (99)	15 (99)	15 (99)	15 (69)
		125 [4.921]	58 (99)	15 (99)	15 (99)	15 (99)	15 (69)
Reed switch type	CS5T CS11T	32 [1.260]	55 (90)	15 (90)	48 (90)	15 (90)	15 (66)
		40 [1.575]	55 (90)	15 (90)	48 (90)	15 (90)	15 (66)
		50 [1.969]	55 (90)	15 (90)	15 (90)	15 (90)	15 (66)
		63 [2.480]	58 (93)	15 (93)	15 (93)	15 (93)	15 (63)
		80 [3.150]	58 (99)	15 (99)	15 (99)	15 (99)	15 (69)
		100 [3.940]	58 (99)	15 (99)	15 (99)	15 (99)	15 (69)
		125 [4.921]	58 (99)	15 (99)	15 (99)	15 (99)	15 (69)
	CS□F	32 [1.260]	55 (93)	33 (93)	55 (93)	25 (93)	20 (93)
		40 [1.575]	55 (93)	33 (93)	55 (93)	25 (93)	20 (93)
		50 [1.969]	55 (93)	33 (93)	55 (93)	25 (93)	20 (93)
		63 [2.480]	55 (96)	33 (96)	55 (96)	25 (96)	20 (96)
		80 [3.150]	55 (101)	33 (101)	25 (101)		20 (101)
		100 [3.940]	55 (99)	33 (106)	25 (106)		20 (106)
		125 [4.921]	55 (99)	33 (106)	25 (106)		20 (106)

Remark: Figures in parentheses ( ) are for trunnion type.

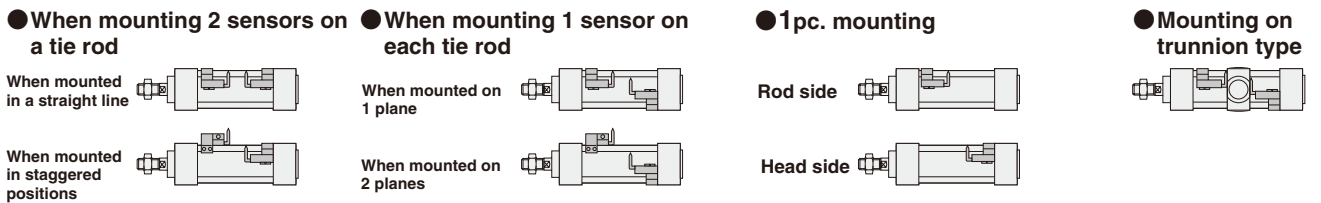

# Sensor Switch Operating Range, Response Differential, and Maximum Sensing Location

## ● ZC1□□ type, CS□T type, CS□F type

### ● Operating range: $l$

The distance the piston travels in one direction, while the switch is in the ON position.

### ● Response differential: C

The distance between the point where the piston turns the switch ON and the point where the switch is turned OFF as the piston travels in the opposite direction.

mm [in.]

Sensor switches model	Solid state type	Reed switch type		
	ZC130, ZC153	CS5T	CS11T	CS□F
Operating range: $l$	2~6 [0.079~0.236]	6~15 [0.236~0.591]		
Response differential: C	1.5 [0.059] MAX.	2.5 [0.098] MAX.		
Maximum sensing location	8.5 [0.335]	7 [0.276]	10.5 [0.413]	16 [0.630]

Notes: 1. Figures in the grommet type are lengths measured from the switch's opposite end side to the lead wire, while the figures in connector type are lengths measured from the connector side's end surface.

2. The above table shows reference values.

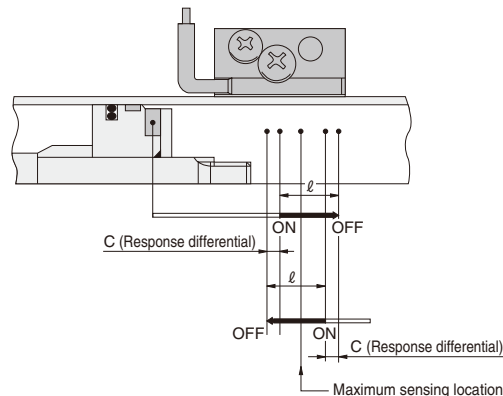

## Mounting Location of Sensor Switch

When the sensor switch is mounted in the locations shown in the diagram (figures in the table are reference values), the magnet comes to the sensor switch's maximum sensing location at the end of the stroke.

### ● Grommet type

### ● Connector type

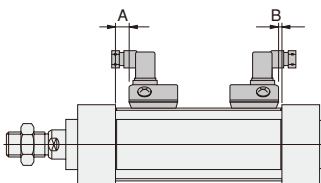
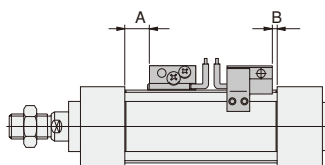

Grommet type enlarged view

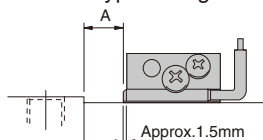

### ● Precaution for mounting

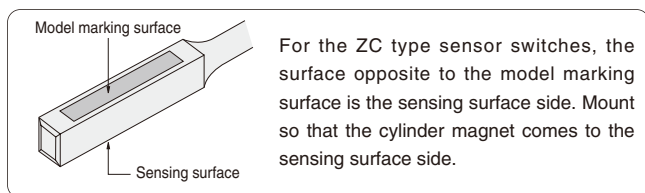

For the ZC type sensor switches, the surface opposite to the model marking surface is the sensing surface side. Mount so that the cylinder magnet comes to the sensing surface side.

### ● Single rod basic type and non-rotating double rod type

mm [in.]

Sensor switch model	Bore size Code	32	40	50	63	80	100	125	
		Solid state type	ZC130 ZC153	A 9 [0.354]	9 [0.354]	9 [0.354]	9.5 [0.374]	12.5 [0.492]	12.5 [0.492]
		B	5 [0.197]	5 [0.197]	5 [0.197]	5.5 [0.217]	6.5 [0.256]	6.5 [0.256]	10.5 [0.413]
Reed switch type	CS5T	A	10.5 [0.413]	10.5 [0.413]	10.5 [0.413]	11 [0.433]	14 [0.551]	14 [0.551]	16 [0.630]
		B	6.5 [0.256]	6.5 [0.256]	6.5 [0.256]	7 [0.276]	8 [0.315]	8 [0.315]	12 [0.472]
	CS11T	A	7 [0.276]	7 [0.276]	7 [0.276]	7.5 [0.295]	10.5 [0.413]	10.5 [0.413]	12.5 [0.492]
		B	3 [0.118]	3 [0.118]	3 [0.118]	3.5 [0.138]	4.5 [0.177]	4.5 [0.177]	8.5 [0.335]
	CS□F	A	3.5 [0.138]	3.5 [0.138]	3.5 [0.138]	4 [0.157]	7 [0.276]	7 [0.276]	9 [0.354]
		B	0	0	0	0	1 [0.039]	1 [0.039]	5 [0.197]

Caution: The reed sensor switch cannot be mounted on the head side in any direction other than that shown in the diagram.

### ● Standard double rod type

mm [in.]

Sensor switch model	Bore size Code	32	40	50	63	80	100	125	
		Solid state type	ZC130 ZC153	A 9.5 [0.374]	9 [0.354]	9.5 [0.374]	9.5 [0.374]	12.5 [0.492]	12.5 [0.492]
		B	4.5 [0.177]	5 [0.197]	4.5 [0.177]	5.5 [0.217]	6.5 [0.256]	6.5 [0.256]	10.5 [0.413]
Reed switch type	CS5T	A	11 [0.433]	10.5 [0.413]	11 [0.433]	11 [0.433]	14 [0.551]	14 [0.551]	16 [0.630]
		B	6 [0.236]	6.5 [0.256]	6 [0.236]	7 [0.276]	8 [0.315]	8 [0.315]	12 [0.472]
	CS11T	A	7.5 [0.295]	7 [0.276]	7.5 [0.295]	7.5 [0.295]	10.5 [0.413]	10.5 [0.413]	12.5 [0.492]
		B	2.5 [0.098]	3 [0.118]	2.5 [0.098]	3.5 [0.138]	4.5 [0.177]	4.5 [0.177]	8.5 [0.335]
	CS□F	A	4 [0.157]	3.5 [0.138]	4 [0.157]	4 [0.157]	7 [0.276]	7 [0.276]	9 [0.354]
		B	0	0	0	0	1 [0.039]	1 [0.039]	5 [0.197]

Caution: The reed sensor switch cannot be mounted on the head side in any direction other than that shown in the diagram.

# Dimensions of Sensor Switch

## ● ZC130, ZC153, CS □ T

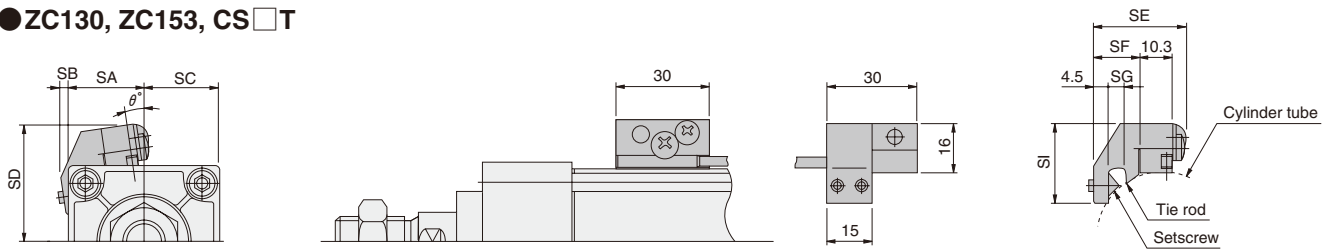

Bois mm [in.]	Code	SA	SB	SC	SD	SE	SF	SG	SI	$\theta$
32 [1.260]		27	5	17	35	29.8	15.5	6	25.5	1
40 [1.575]		26.1	2	23.9	38.4	29.8	15.5	6	25.5	10
50 [1.969]		27.1	0.7	34.9	43.4	29.8	15.5	6	25.5	10
63 [2.480]		28.3	0	46.7	48.6	31.8	17.5	8	24.5	18
80 [3.150]		30.9	0	63.1	55.9	33.3	19	9.5	22.5	22
100 [3.940]		32.2	0	79.8	63.6	33.3	19	9.5	22.5	24.5
125 [4.921]		36.5	—	99.5	75	37.5	24.8	11	15.5	27.5

## ● CS □ F

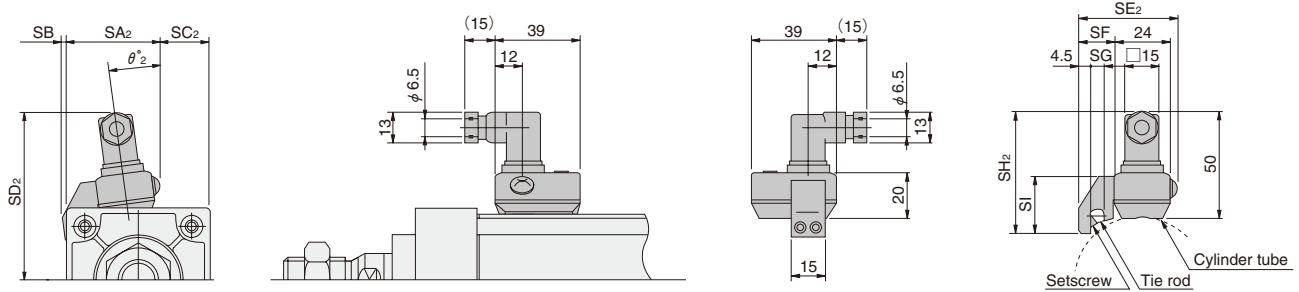

Bois mm [in.]	Code	SA <sub>2</sub>	SB	SC <sub>2</sub>	SD <sub>2</sub>	SE <sub>2</sub>	SF	SG	SH <sub>2</sub>	SI	$\theta_2$
32 [1.260]		41.5	5	2.5	66.5	43	15.5	6	56.5	25.5	2.3
40 [1.575]		33.5	1.5	16.5	70	43	15.5	6	56.5	25.5	12
50 [1.969]		40	0.5	22	74.5	43	15.5	6	56.5	25.5	10
63 [2.480]		40.5	0	34.5	79.5	45	17.5	6	55.5	24.5	19
80 [3.150]		42.5	—	51.5	86	46.5	19	9.5	53.5	22.5	23
100 [3.940]		44	—	68	93.5	46.5	19	9.5	53.5	22.5	25
125 [4.921]		49.5	—	86.5	106.5	52.5	25	11	50.5	15.5	23.5

# Instructions for Mounting and Moving Sensor Switch

## ZC1□□, CS□T types

Requiring parts for mounting 1 sensor switch on a cylinder

- ① Sensor Switch
- ② Washer × 1
- ③ Screw (short) × 1
- ④ Sensor holder × 1
- ⑤ Setscrew × 2
- ⑥ Tie rod
- ⑦ Screw (long) × 1
- ⑧ Sub-holder × 1

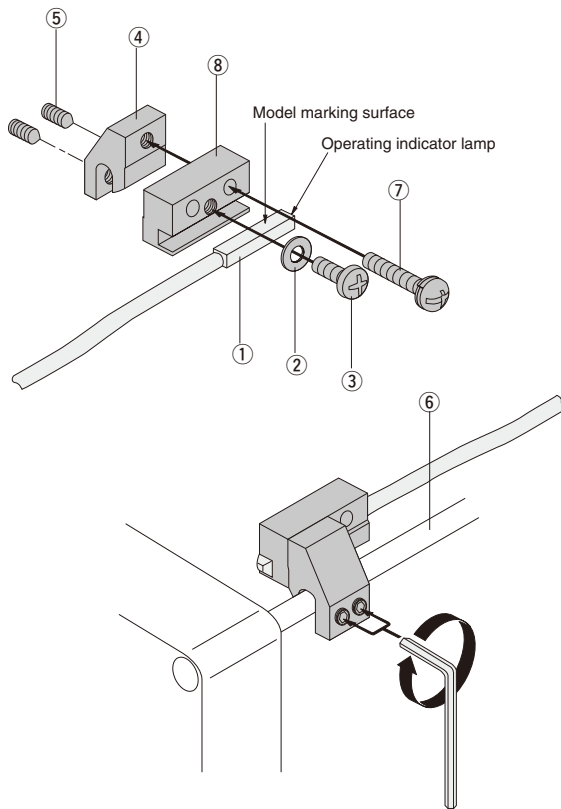

1. ● Align the female thread of sensor holder ④ to the position of the sub-holder ⑧'s thru hole, and use a screw (long) ⑦ to assemble.
  - Two thru holes are available for ⑧. Either one can be used.
  - The appropriate tightening torque for ⑦ is 70 N-cm [6.2in-lbf].
2. ● Install the sensor switch ① with the model marking surface facing upward, and fit it on the groove of ⑧.
  - Align the edges of the body ① and indicator lamp (or the cap) to the end plane of ⑧, and assemble. To protect ①, always assemble so that the body ① does not protrude from the end surface of ⑧.
  - The appropriate tightening torque for the screw (short) ③ is 70N-cm [6.2in-lbf].
3. ● Two setscrews ⑤ are temporarily fixed ④ in place.
  - Fit ④ that was assembled with ① and ⑧ onto the tie rod ⑥, and align it to the designated position. Then use an Allen wrench (width across flats B = 2) to tighten ⑤ and secure it in place. Always secure it so that the bottom surface of ⑧ is in contact with the cylinder tube.
  - The appropriate tightening torque for ⑤ is 70 N-cm [6.2in-lbf].
  - There are four ⑥s on the cylinder, and ④ can be installed on any of them. In addition, ④ can be fitted in any direction.
  - Loosening the 2 screws ⑤ allows ④ to be moved freely along ⑥.

DYNA CYLINDERS

## CS□F type

Requiring parts for mounting 1 sensor switch on a cylinder

- ① Sensor Switch
- ② Washer × 1
- ③ Screw × 1
- ④ Sensor holder × 1
- ⑤ Setscrew × 2
- ⑥ Tie rod

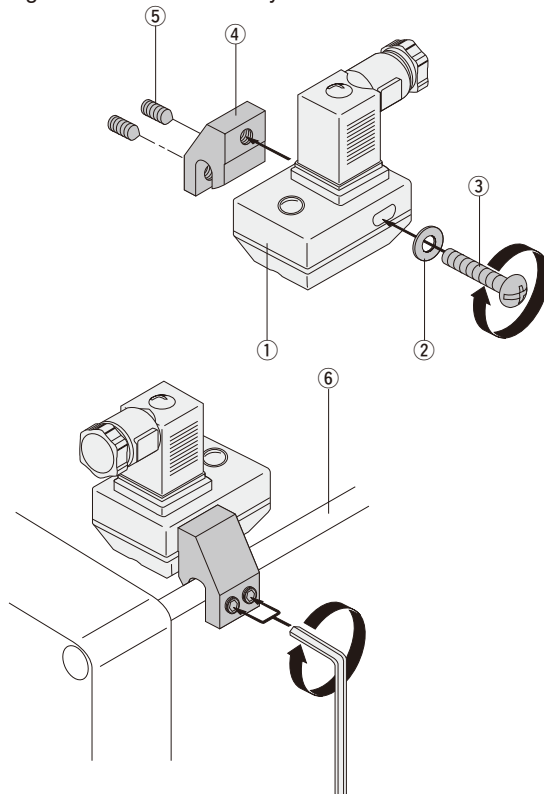

1. ● For the sensor switch ①, align the female thread of sensor holder ④ to any required location of the ①'s thru hole (oval), and assemble.
  - The appropriate tightening torque for the screw ③ is 70N-cm [6.2in-lbf].
2. ● Use 2 setscrews ⑤ to temporarily fix ④ in place.
  - Fit ④ that was assembled with ① onto the tie rod ⑥, and align it to the designated position. Then use an Allen wrench (width across flats B = 2) to tighten ⑤ and secure it in place. Always secure it so that the bottom surface of ① is in contact with the cylinder tube.
  - To detect the head side end of stroke, mount ① so that the connector wiring port faces toward the head cover side, as shown in the diagram to the left.
  - The appropriate tightening torque for ⑤ is 70N-cm [6.2in-lbf].
  - There are four ⑥s on the cylinder, and ④ can be installed on any of them. In addition, ④ can be fitted in any direction.
  - Loosening the 2 screws ⑤ allows ④ to be moved freely along ⑥.

# KNUCKLES AND BELLOWS

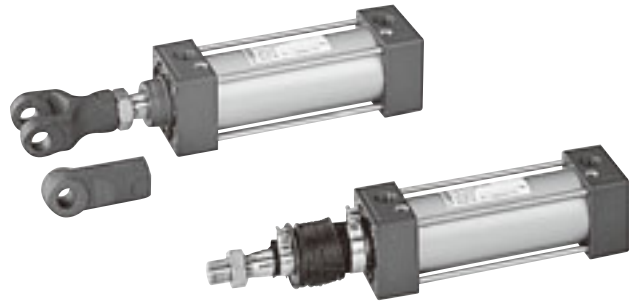

## Dimensions of Knuckle (mm)

### ● Y type

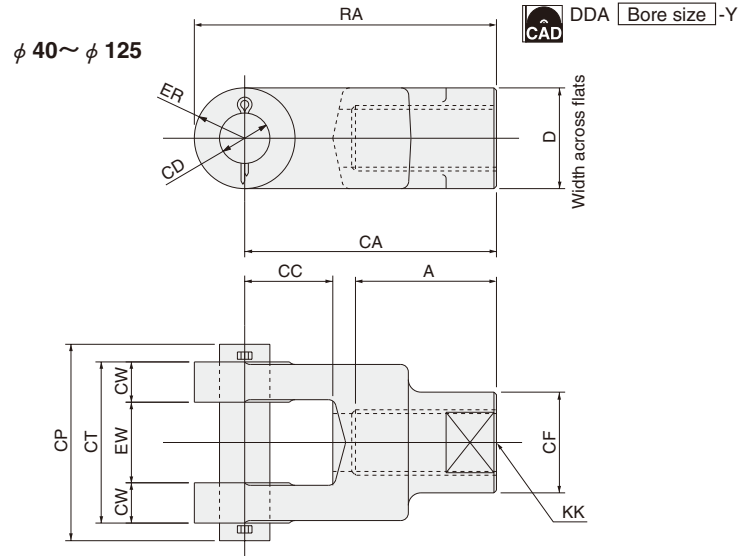
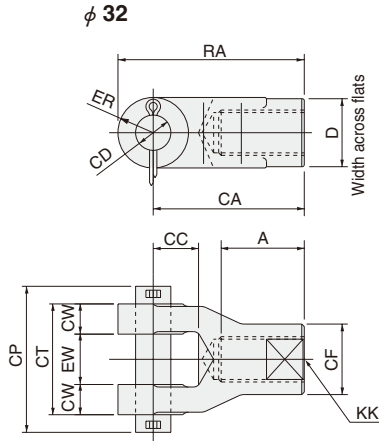

Bore mm [in.]	Code	A	CA	CC	CD	CF	CP	CT	CW	D	ER	EW	KK (other than non-rotating)	KK (non-rotating)	RA
32 [1.260]		23	55	20	$\phi 12_{H9/f8}$	$\phi 24$	46	32	8	24	R12	$16^{+1.5}_{+0.5}$	M10×1.25	—	67
40 [1.575]		18	46	16	$\phi 12_{H9/f8}$	$\phi 25$	48	36	9	—	R12.5	$18^{+0.4}_{+0.1}$	M14×1.5	M12×1.25	58.5
50 [1.969]		22	46	16	$\phi 12_{H9/f8}$	$\phi 25$	48	36	9	—	R12.5	$18^{+0.4}_{+0.1}$	M18×1.5	M18×1.5	58.5
63 [2.480]		22	50	20	$\phi 16_{H9/f8}$	$\phi 32$	56	44	11	—	R16	$22^{+0.4}_{+0.1}$	M18×1.5	M18×1.5	66
80 [3.150]		30	75	25	$\phi 20_{H9/f8}$	$\phi 40$	68	56	14	—	R20	$28^{+0.4}_{+0.1}$	M22×1.5	M22×1.5	95
100 [3.940] (other than non-rotating)		34	75	25	$\phi 20_{H9/f8}$	$\phi 40$	68	56	14	—	R20	$28^{+0.4}_{+0.1}$	M26×1.5	—	95
100 [3.940] (non-rotating)		34	75	25	$\phi 20_{H9/f8}$	$\phi 40$	68	56	14	—	R20	$28^{+0.4}_{+0.1}$	—	M22×1.5	95
125 [4.921]		56	100	35	$\phi 20_{H9/f8}$	$\phi 40$	78	64	16	40	R20	$32^{+1.5}_{+0.5}$	M27×2	—	120

### ● I type

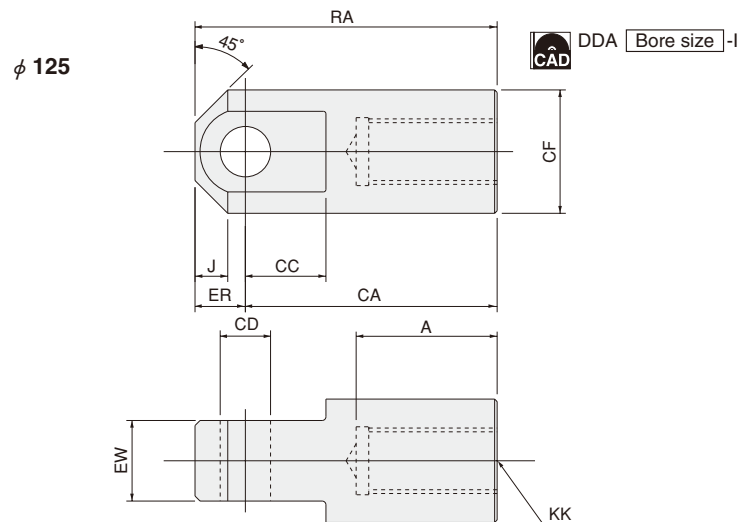
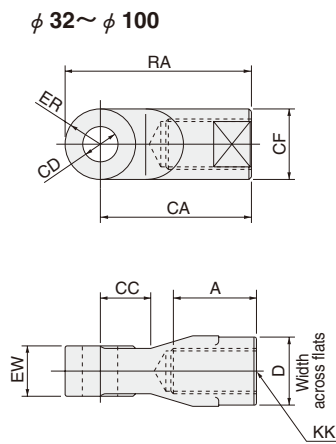

Bore mm [in.]	Code	A	CA	CC	CD	CF	D	ER	EW	J	KK (other than non-rotating)	KK (non-rotating)	RA
32 [1.260]		23	55	20	$\phi 12_{H9}$	$\phi 24$	24	R12	$16^{0}_{-0.1}$	—	M10×1.25	—	67
40 [1.575]		18	46	16	$\phi 12_{H9}$	$\phi 25$	—	R12.5	$18^{0}_{-0.1}$	—	M14×1.5	M12×1.25	58.5
50 [1.969]		22	46	16	$\phi 12_{H9}$	$\phi 25$	—	R12.5	$18^{0}_{-0.1}$	—	M18×1.5	M18×1.5	58.5
63 [2.480]		22	50	20	$\phi 16_{H9}$	$\phi 32$	—	R16	$22^{0}_{-0.1}$	—	M18×1.5	M18×1.5	66
80 [3.150]		30	75	25	$\phi 20_{H9}$	$\phi 40$	—	R20	$28^{0}_{-0.1}$	—	M22×1.5	M22×1.5	95
100 [3.940] (other than non-rotating)		34	75	25	$\phi 20_{H9}$	$\phi 40$	—	R20	$28^{0}_{-0.1}$	—	M26×1.5	—	95
100 [3.940] (non-rotating)		34	75	25	$\phi 20_{H9}$	$\phi 40$	—	R20	$28^{0}_{-0.1}$	—	—	M22×1.5	95
125 [4.921]		56	100	32	$\phi 20_{H9}$	$\phi 49$	—	20	$32^{0}_{-0.1}$	13	M27×2	—	120

## Dimensions of Bellows (mm [in.])

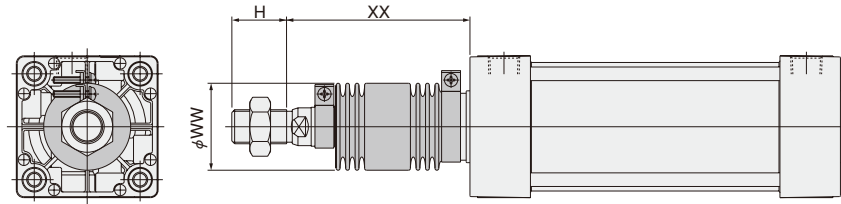

Bore size mm [in.]	Code	WW				XX				H
		Nylon tarpaulin	Chloroprene	Conex	Alumix	Nylon tarpaulin	Chloroprene	Conex	Alumix	
32 [1.260]		36 [1.42]	36 [1.42]	61 [2.40]	36 [1.42]	1/3 stroke + 48 [1.89]	1/3 stroke + 48 [1.89]	1/2 stroke + 48 [1.89]	1/2 stroke + 48 [1.89]	19 [0.75]
40 [1.575]		41 [1.61]	41 [1.61]	61 [2.40]	41 [1.61]					21 [0.83]
50 [1.969]		47 [1.85]	47 [1.85]	61 [2.40]	47 [1.85]	1/3 stroke + 53 [2.09]	1/3 stroke + 53 [2.09]	1/2 stroke + 53 [2.09]	1/2 stroke + 53 [2.09]	29 [1.14]
63 [2.480]		47 [1.85]	47 [1.85]	61 [2.40]	47 [1.85]					29 [1.14]
80 [3.150]		56 [2.20]	56 [2.20]	61 [2.40]	56 [2.20]	1/4 stroke + 58 [2.28]	1/4 stroke + 58 [2.28]	2/5 stroke + 58 [2.28]	2/5 stroke + 58 [2.28]	37 [1.46]
100 [3.940]		61 [2.40]	61 [2.40]	61 [2.40]	61 [2.40]					37 [1.46]
125 [4.921]		71 [2.80]	71 [2.80]	71 [2.80]	71 [2.80]	1/4 stroke + 59 [2.32]	1/4 stroke + 59 [2.32]	2/5 stroke + 59 [2.32]	2/5 stroke + 59 [2.32]	50 [1.97]

### ● Bellows Specifications

Type	Specifications	Contents	Heat resistant temperature °C [°F]
Nylon tarpaulin (standard)		Coating vinyl to nylon cloth	80 [176]
Chloroprene		Coating chloroprene to nylon cloth	100 [212]
Conex		Coating silicone to Conex cloth (no use of asbestos)	200 [392]
Alumix		Coating aluminum foil to asbestos cloth	250 [482]

Note: The temperatures shown are the bellows' own durable temperatures, and are not temperatures for cylinder use.

## Order Codes of Mounting Brackets and Knuckles

### ● Mounting bracket



#### Cylinder type

- NDDA — DYNA cylinder
- NDDAR — DYNA cylinder with brake
- NDDAE — DYNA pull side stroke adjusting cylinder
- NDDAP — DYNA push side stroke adjusting cylinder

#### Mounting bracket

- 1 — Foot mounting type (One set of 2 units)
- 2 — Axial foot mounting type (One set of 2 units)
- 3 — Rod side flange mounting type<sup>Note</sup>
- 5 — Head side flange mounting type
- 7 — Clevis mounting type (with pin)
- 7-7C — Clevis mounting type (with supporting bracket)
- 8 — Pivot mounting type
- 11 — Trunnion type
- 11-11T — Trunnion type (with supporting brackets)

Note: The rod side flange cannot be retrofitted with the bellows type.

#### Bore size

- 32 — For φ 32 [1.260in.]
- 40 — For φ 40 [1.575in.]
- 50 — For φ 50 [1.969in.]
- 63 — For φ 63 [2.480in.]
- 80 — For φ 80 [3.150in.]
- 100 — For φ 100 [3.940in.]
- 125 — For φ 125 [4.921in.]

### ● Y, I type knuckle



#### Cylinder type

- NDDA — DYNA cylinder
- NDDAL — DYNA non-rotating cylinder

#### Knuckles

- Y — Y type knuckle
- I — I type knuckle

● For dimensions of knuckle, see p.537.

#### Bore size

- 32 — For φ 32 [1.260in.]
- 40 — For φ 40 [1.575in.]
- 50 — For φ 50 [1.969in.]
- 63 — For φ 63 [2.480in.]
- 80 — For φ 80 [3.150in.]
- 100 — For φ 100 [3.940in.]
- 125 — For φ 125 [4.921in.]

## Maximum Available Stroke of Cylinder with Bellows

Bellows model / Bore size	mm [in.]	
	φ 32 [1.260]~ φ 63 [2.480]	φ 80 [3.150]~ φ 125 [4.921]
JT	Maximum available St×3/4-50	Maximum available St×4/5-50
JC	Maximum available St×3/4-50	Maximum available St×4/5-50
<td>Maximum available St×2/3-50</td> <td>Maximum available St×2/3-50</td>	Maximum available St×2/3-50	Maximum available St×2/3-50
JA	Maximum available St×2/3-50	Maximum available St×2/3-50