

# Slit type rodless cylinders ORS series

# Magnet type rodless cylinders MRS series

## High Rigidity

Maximum load capacity : 600N [135lbf.] (ORS32,40/MRS32,40)  
Pitching moment : 60N·m [44.3ft·lbf] (ORS32,40/MRS32,40)

## Shock Absorber Units are Standard Equipment.

Since shock absorber unit provides positioning of the end of the stroke, it enhances absorbing capacity to the maximum extent. The shock absorber does not protrude beyond the end plate. Moreover, moving the shock absorber unit is all that is required to adjust the stroke all along its range.



## Specified Stroke **Plus** 10mm [0.394in.]

Since the shock absorber can be used for fine stroke adjustment of +5mm [0.197in.] for one side, it totally offers a +10mm [0.394in.] margin in regards to the specified stroke.

## Heli-serts in the Table's Mounting Threads are Optional.



## Versatile Mounting Direction

More versatile mounting, with direct mounting at the end plate, or mounting with T-slots on the bottom surface.

(While mounting dimensions are the same for ORS and MRS, the table height varies.)

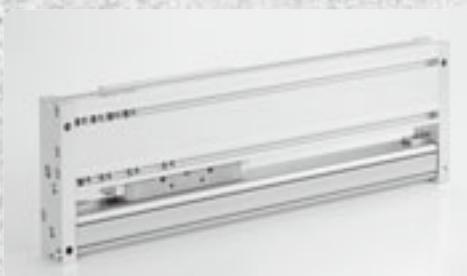

## Connection Ports Integrated onto Single Plane

Concentrated connection ports as standard equipment save space.



Slit Type Rodless Cylinders  
ORS series

## Uses Embedded Type Sensor Switch

Easily and clearly pulling out lead wires from the grooves on the body.



● The greatest part of its appeal is **its low center of gravity.**

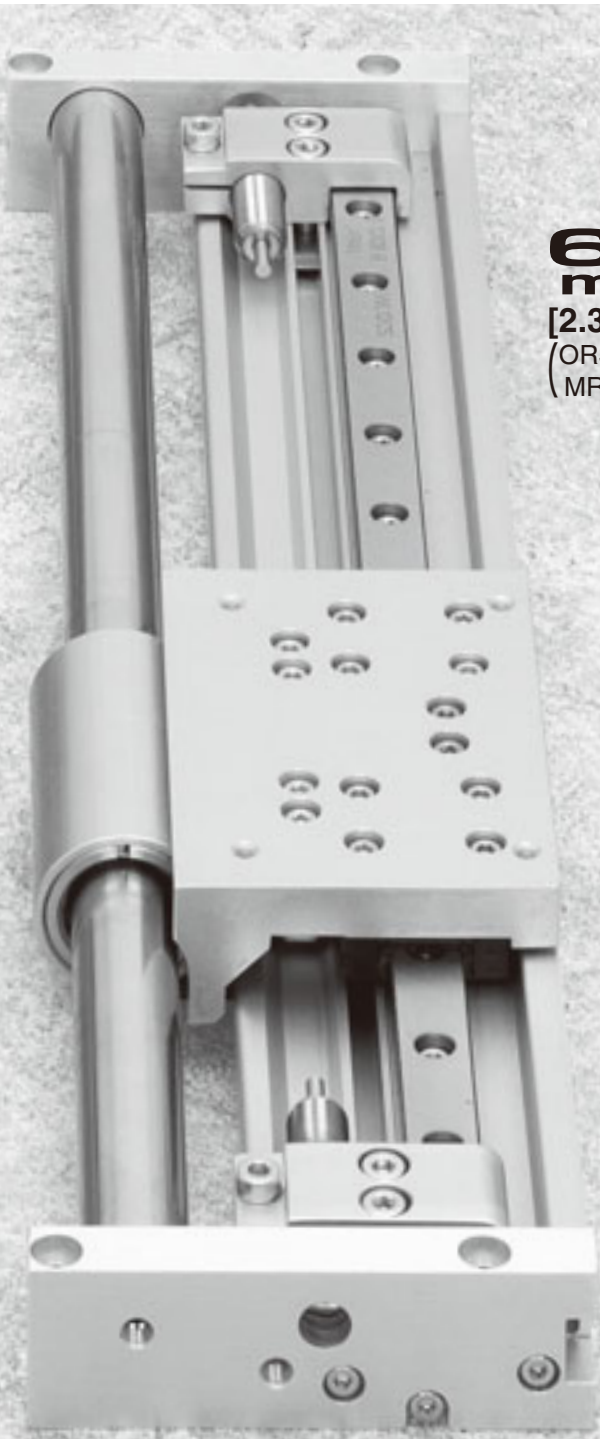

**60 mm**  
[2.362in.]  
(ORS32,40)  
(MRS32)

**φ 40** [1.575in.]



**40 mm**  
[1.575in.]  
(ORS20,25)  
(MRS20)

**φ 25** [0.984in.]

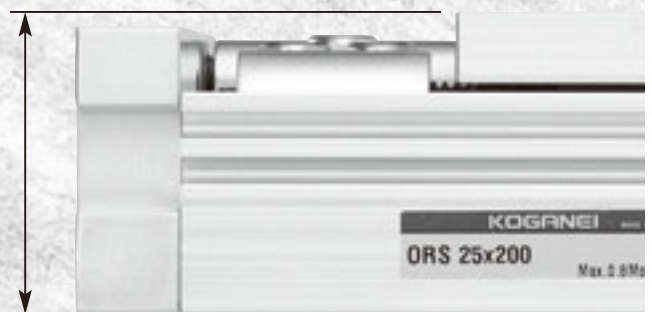

**30 mm**  
[1.181in.]  
(ORS10,16)  
(MRS10)

**φ 10** [0.394in.]

**φ 16** [0.630in.]

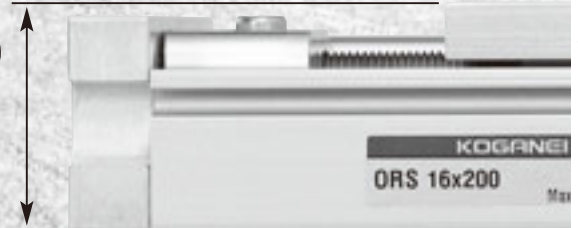

The table height is designed to be extremely low, to make thin-shape device design possible. The low-profile table improves double axis applications.

Magnet type rodless cylinders  
**MRS series**

SLIT TYPE RODLESS CYLINDERS ORS SERIES/MAGNET TYPE RODLESS CYLINDERS MRS SERIES

## Handling Instructions and Precautions

---



### General precautions

#### Piping

Always thoroughly blow off (use compressed air) the tubing before connecting it to the rodless cylinder. Entering chips, sealing tape, rust, etc., generated during piping work could result in air leaks or other defective operation.

#### Atmosphere

1. If using in locations subject to dripping water, dripping oil, etc., or to large amounts of dust, use a cover to protect the unit or mount with the slider facing downward.
2. Do not engage in electric welding close to the rodless cylinders **ORS**, **MRS** series. The welding spatters could damage the outer seal band, etc.
3. The product cannot be used when the media or ambient atmosphere contains any of the substances listed below.  
Organic solvents, phosphate ester type hydraulic oil, sulphur dioxide, chlorine gas, or acids, etc.

#### Lubrication

1. The product can be used without lubrication, if lubrication is required, use Turbine Oil Class 1 (ISO VG32) or lithium soap-based No. 2 or their equivalents.
2. The **MRS** series requires periodic greasing. Apply the recommended grease to the cylinder tube's outer surface every 300km [186mi.] of traveling distance.  
Moreover, at 6 month intervals, or every 300km [186mi.] of traveling distance, apply lithium soap-based grease on the raceway surface of the track rail.

#### <Recommended grease>

**MRS** series: Fluorine-contained lithium type grease

#### Media

1. Use air for media. Consult us for the use of any other media.
2. Air used for the rodless cylinders **ORS**, **MRS** series should be clean air that contains no moisture, dust, oxidized oil, or other foreign material in the compressed air. Install an air filter (filtration of a minimum 40 µm) near the rodless cylinders **ORS**, **MRS** series or valve to remove collected liquid or dust. In addition, drain the air filter periodically.

# SLIT TYPE RODLESS CYLINDERS ORS SERIES



## Symbol

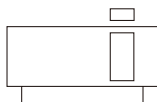

## Specifications

| Item                         | Bore size<br>mm [in.] | 10 [0.394]   | 16 [0.630] | 20 [0.787]   | 25 [0.984] | 32 [1.260] | 40 [1.575] |
|------------------------------|-----------------------|--|------------|--|------------|------------|------------|
| Operation type               |                       | Double acting type   |            |  |            |            |            |
| Media                        |                       | Air  |            |  |            |            |            |
| Operating pressure range     | MPa [psi.]            | 0.25~0.7 [36~102]  |            | 0.15~0.8 [22~116]                                  |            |            |            |
| Proof pressure               | MPa [psi.]            | 1.05 [152]   |            | 1.2 [174]  |            |            |            |
| Operating temperature range  | °C [°F]               | 0~60 [32~140]  |            |  |            |            |            |
| Operating speed range        | mm/s [in./sec.]       | 150~1000 [5.9~39.4]<br>(2000 [78.7]) <sup>Note2</sup>  |            | 100~1000 [3.9~39.4] (2000 [78.7]) <sup>Note2</sup> |            |            |            |
| Cushion                      |                       | Shock absorber (Standard equipment for both ends)  |            |  |            |            |            |
| Lubrication                  | Cylinder portion      | Not required (If lubrication is required, use Turbine Oil Class 1 [ISO VG32] or equivalent, or lithium soap-based grease.) |            |  |            |            |            |
|                              | Guide portion         | Required (Lithium soap-based grease)   |            |  |            |            |            |
| Repeatability                | mm [in.]              | ±0.05 [±0.002]   |            |  |            |            |            |
| Parallelism <sup>Note1</sup> | mm [in.]              | 0.3 [0.012]  |            |  |            |            |            |
| Stroke adjusting range       | mm [in.]              | Adjustable over the entire stroke (Specified stroke +10mm [0.394])   |            |  |            |            |            |
| Maximum load capacity        | N [lbf.]              | 130 [29.2]   |            | 300 [67.4]   |            | 600 [135]  |            |
| Port size                    |                       | M5×0.8   |            | Rc1/8  |            | Rc1/4      |            |

Notes: 1. This is the parallelism between the upper surface of the table and the bottom of the body. It is not the same as the traveling parallelism.

2. Figures in parentheses ( ) are for when ORS series with shock absorbers are set for 2000mm/s [78.7in./sec.] impact speed.

Remark: For the relation between the mass and piston speed, see the shock absorber absorption capacity graph on p.1196.

## Specifications of Shock Absorber

| Item                                | Model               | KSHJ10×10-01  | KSHJ10×10-02 | KSHJ14×12-01 | KSHJ14×12-02 | KSHJ20×16-01 | KSHJ20×16-02 |
|-------------------------------------|---------------------|---------------|--------------|--------------|--------------|--------------|--------------|
| Applicable cylinder                 |                     | ORS10, ORS16  |              | ORS20, ORS25 |              | ORS32, ORS40 |              |
| Maximum absorption                  | J [ft-lbf]          | 3 [2.2]       |              | 10 [7.4]     |              | 30 [22.1]    |              |
| Absorbing stroke                    | mm [in.]            | 10 [0.394]    |              | 12 [0.472]   |              | 16 [0.630]   |              |
| Maximum impact speed                | mm/s [in./sec.]     | 1000 [39.4]   | 2000 [78.7]  | 1000 [39.4]  | 2000 [78.7]  | 1000 [39.4]  | 2000 [78.7]  |
| Maximum operating frequency         | cycle/min           | 60            |              | 40           |              | 30           |              |
| Maximum absorption per minute       | J/min [ft-lbf/min.] | 120 [88.5]    |              | 240 [177]    |              | 450 [332]    |              |
| Spring return force <sup>Note</sup> | N [lbf.]            | 8.0 [1.80]    |              | 9.2 [2.07]   |              | 22.0 [4.95]  |              |
| Angle variation                     |                     | 1° or less    |              |              |              | 3° or less   |              |
| Operating temperature range         | °C [°F]             | 0~60 [32~140] |              |              |              |              |              |

Note: Values at retracted position.

Caution: The life of the shock absorber may vary from the Slit Type Rodless Cylinder, depending on its operating conditions.

## Cylinder Thrust

| Bore size<br>mm [in.] | Pressure area<br>mm <sup>2</sup> [in. <sup>2</sup> ] | Air pressure MPa [psi.] |            |             |             |             |             |              |
|-----------------------|--|-------------------------|------------|-------------|-------------|-------------|-------------|--------------|
|                       |  | 0.2 [29]                | 0.3 [44]   | 0.4 [58]    | 0.5 [73]    | 0.6 [87]    | 0.7 [102]   | 0.8 [116]    |
| 10 [0.394]            | 78.5 [0.122]   | —                       | 24 [5.4]   | 31 [7.0]    | 39 [8.8]    | 47 [10.6]   | 55 [12.4]   | —            |
| 16 [0.630]            | 201 [0.312]  | 40 [9.0]                | 60 [13.5]  | 80 [18.0]   | 101 [22.7]  | 121 [27.2]  | 141 [31.7]  | 161 [36.2]   |
| 20 [0.787]            | 314 [0.487]  | 63 [14.2]               | 94 [21.1]  | 126 [28.3]  | 157 [35.3]  | 188 [42.3]  | 220 [49.5]  | 251 [56.4]   |
| 25 [0.984]            | 490 [0.760]  | 98 [22.0]               | 147 [33.0] | 196 [44.1]  | 245 [55.1]  | 294 [66.1]  | 343 [77.1]  | 392 [88.1]   |
| 32 [1.260]            | 804 [1.246]  | 161 [36.2]              | 241 [54.2] | 322 [72.4]  | 402 [90.4]  | 482 [108.4] | 563 [126.6] | 643 [144.5]  |
| 40 [1.575]            | 1256 [1.947]   | 251 [56.4]              | 377 [84.7] | 502 [112.8] | 628 [141.2] | 754 [169.5] | 879 [197.6] | 1005 [225.9] |

## Bore Size and Stroke

| Bore size | Standard strokes                    | Available strokes |
|-----------|-------------------------------------|-------------------|
| 10        | 150,200,250,300,350,400,500,600     | 50~2000           |
| 16        | 150,200,250,300,350,400,500,600     | 50~3000           |
| 20        | 200,250,300,350,400,500,600,700,800 | 50~3000           |
| 25        | 200,250,300,350,400,500,600,700,800 | 50~3000           |
| 32        | 200,250,300,350,400,500,600,700,800 | 50~3000           |
| 40        | 300,400,500,600,700,800,900,1000    | 50~3000           |

Remark: Non-standard strokes are available at each 50mm stroke. For delivery, consult us .

## Mass

| Bore size<br>mm [in.] | Zero stroke mass | Additional mass for each<br>50mm [1.969in.] stroke | Additional mass of 1 sensor switch <sup>Note</sup> |               |
|-----------------------|------------------|--|--|---------------|
|                       |                  |  | ZE□□□A   | ZE□□□B        |
| 10 [0.394]            | 0.85 [1.87]      | 0.13 [0.29]  | 0.015 [0.033]                                      | 0.035 [0.077] |
| 16 [0.630]            | 0.96 [2.12]      | 0.15 [0.33]  |  |               |
| 20 [0.787]            | 2.65 [5.84]      | 0.29 [0.64]  |  |               |
| 25 [0.984]            | 2.77 [6.11]      | 0.31 [0.68]  |  |               |
| 32 [1.260]            | 6.41 [14.13]     | 0.51 [1.12]  |  |               |
| 40 [1.575]            | 7.30 [16.10]     | 0.55 [1.21]  |  |               |

Note: Sensor switch types A and B show the lead wire lengths.

A : 1000mm [39in.] B : 3000mm [118in.]

## Air Flow Rate and Air Consumption

While the rodless cylinder's air flow rate and air consumption can be found through the following calculations, the quick reference tables below provides the answers more conveniently.

$$\text{Air flow rate: } Q_1 = \frac{\pi D^2}{4} \times L \times \frac{60}{t} \times \frac{P+0.101}{0.101} \times 10^{-6}$$

$$\text{Air consumption: } Q_2 = \frac{\pi D^2}{4} \times L \times 2 \times n \times \frac{P+0.101}{0.101} \times 10^{-6}$$

Q<sub>1</sub> : Required air flow rate for cylinder ℓ /min(ANR)  
 Q<sub>2</sub> : Air consumption of cylinder ℓ /min(ANR)  
 D : Cylinder tube inner diameter mm  
 L : Cylinder stroke mm  
 t : Time required for cylinder to travel 1 stroke s  
 n : Number of cylinder reciprocations per minute times/min  
 P : Pressure MPa

$$\text{Air flow rate: } Q_1' = \frac{\pi D'^2}{4} \times L' \times \frac{60}{t} \times \frac{P'+14.7}{14.7} \times \frac{1}{1728}$$

$$\text{Air consumption: } Q_2' = \frac{\pi D'^2}{4} \times L' \times 2 \times n \times \frac{P'+14.7}{14.7} \times \frac{1}{1728}$$

Q<sub>1</sub>' : Required air flow rate for cylinder ft<sup>3</sup>/min.(ANR)\*  
 Q<sub>2</sub>' : Air consumption of cylinder ft<sup>3</sup>/min.(ANR)\*  
 D' : Cylinder tube inner diameter in.  
 L' : Cylinder stroke in.  
 t : Time required for cylinder to travel 1 stroke sec.  
 n : Number of cylinder reciprocations per minute times/min  
 P' : Pressure psi.

\* Refer to p.54 for an explanation of ANR.

cm<sup>3</sup> [in.<sup>3</sup>]/Reciprocation (ANR)

| Bore size<br>mm [in.] | Air pressure MPa [psi.] |                |                |                |                |                 |                 |
|-----------------------|-------------------------|----------------|----------------|----------------|----------------|-----------------|-----------------|
|                       | 0.2 [29]                | 0.3 [44]       | 0.4 [58]       | 0.5 [73]       | 0.6 [87]       | 0.7 [102]       | 0.8 [116]       |
| 10 [0.394]            | —                       | 0.623 [0.0380] | 0.779 [0.0475] | 0.934 [0.0570] | 1.090 [0.0665] | 1.245 [0.0760]  | —               |
| 16 [0.630]            | 1.198 [0.0731]          | 1.596 [0.0974] | 1.993 [0.1216] | 2.391 [0.1459] | 2.789 [0.1702] | 3.187 [0.1945]  | 3.585 [0.2188]  |
| 20 [0.787]            | 1.872 [0.1142]          | 2.493 [0.1521] | 3.115 [0.1901] | 3.737 [0.2280] | 4.359 [0.2660] | 4.980 [0.3039]  | 5.602 [0.3419]  |
| 25 [0.984]            | 2.924 [0.1784]          | 3.896 [0.2377] | 4.867 [0.2970] | 5.838 [0.3563] | 6.810 [0.4156] | 7.781 [0.4748]  | 8.753 [0.5341]  |
| 32 [1.260]            | 4.792 [0.2924]          | 6.384 [0.3896] | 7.976 [0.4867] | 9.568 [0.5839] | 11.16 [0.6810] | 12.753 [0.7782] | 14.345 [0.8754] |
| 40 [1.575]            | 7.486 [0.4568]          | 9.973 [0.6086] | 12.46 [0.7604] | 14.95 [0.9123] | 17.43 [1.0636] | 19.92 [1.2156]  | 22.41 [1.3675]  |

The figures in the table show the air flow rate and air consumption when a rodless cylinder makes 1 reciprocation with stroke of 1mm [0.0394in.]. The air flow rate and consumption actually required are found by the following calculations.

- Finding the air flow rate (for selecting F.R.L., valves, etc.)

Example: When operating a rodless cylinder with bore size of 40mm [1.575in.] at speed of 300mm/s [11.8in./sec.] and under air pressure of 0.5Mpa [73psi.]

$$14.95 \times \frac{1}{2} \times 300 \times 10^{-3} = 2.24 \text{ } \ell/\text{s} [0.0791\text{ft}^3/\text{sec.}] \text{ (ANR)}$$

$$\text{(At this time, the air flow rate per minute is } 14.95 \times \frac{1}{2} \times 300 \times 60 \times 10^{-3} = 134.55 \text{ } \ell/\text{min} [4.750\text{ft}^3/\text{min.}] \text{ (ANR).)}$$

- Finding the air consumption

Example 1. When operating a rodless cylinder with bore size of 40mm [1.575in.] and stroke of 100mm [3.94in.], and under air pressure of 0.5MPa [73psi.], for 1 reciprocation

$$14.95 \times 100 \times 10^{-3} = 1.495 \text{ } \ell [0.0528\text{ft}^3]/\text{Reciprocation (ANR)}$$

Example 2. When operating a rodless cylinder with bore size of 40mm [1.575in.] and stroke of 100mm [3.94in.], and under air pressure of 0.5MPa [73psi.], for 10 reciprocations per minute

$$14.95 \times 100 \times 10 \times 10^{-3} = 14.95 \text{ } \ell/\text{min} [0.528\text{ft}^3/\text{min.}] \text{ (ANR)}$$

Note: To find the actual air consumption required when using rodless cylinders, add the air consumption of the piping to the air consumption obtained from the above calculation.

Moreover, for the slit type rodless cylinder ORS series, add 1 ℓ/min [0.0353ft<sup>3</sup>/min.] (ANR) as air leakage from the slit.

# Order Codes for Slit Type Rodless Cylinders

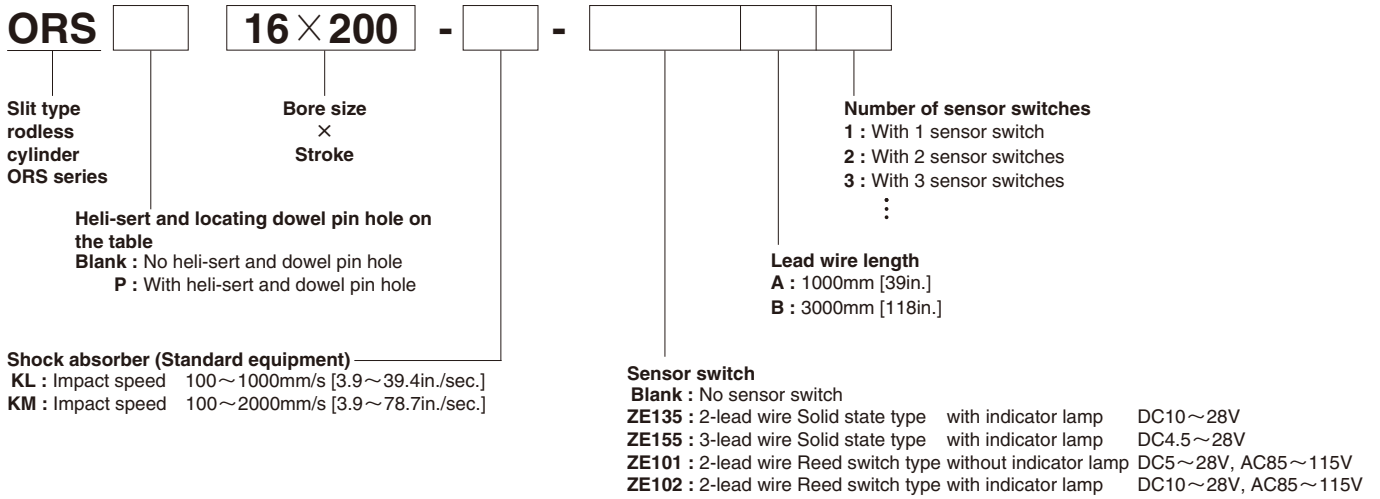

## Additional Parts

### ● Shock absorber

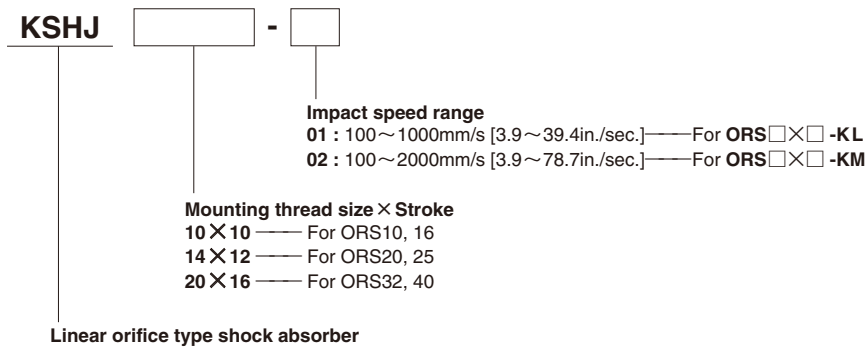

SLIT TYPE RODLESS CYLINDERS ORS SERIES/MAGNET TYPE RODLESS CYLINDERS MRS SERIES

## Inner Construction of Slit Type Rodless Cylinder

ORS ( $\phi 16 \sim \phi 40$ )

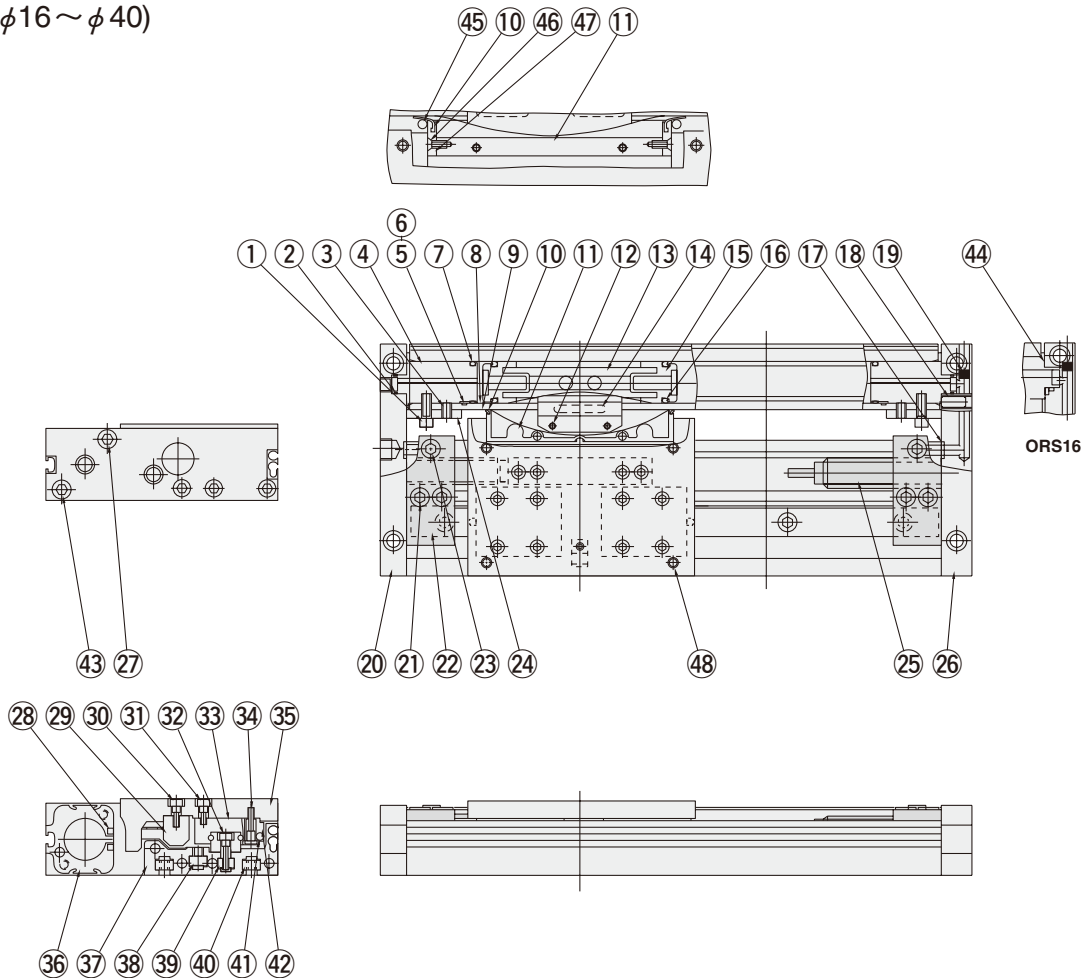

### Major Parts and Materials

| No. | Parts                    | Materials              | Q'ty | Remarks   |
|-----|--------------------------|------------------------|------|---|
| ①   | Hexagon socket head bolt | Alloy steel            | 2    | Zinc plated   |
| ②   | Plate gasket             | Synthetic rubber (NBR) | 2    |   |
| ③   | Hexagon socket setscrew  | Alloy steel            | 2    | Black oxide   |
| ④   | End pipe                 | Aluminum alloy         | 2    |   |
| ⑤   | Rivet                    | Brass                  | 2    |   |
| ⑥   | Band washer              | Brass                  | 2    |   |
| ⑦   | Cylinder gasket          | Synthetic rubber (NBR) | 2    |   |
| ⑧   | Inner seal band          | Stainless chrome steel | 1    |   |
| ⑨   | Outer seal band          | Stainless chrome steel | 1    |   |
| ⑩   | Scraper                  | Nylon                  | 1    | For $\phi 40$ [1.575in.], polyacetal, 2pcs.           |
| ⑪   | Piston mount             | Aluminum alloy         | 1    | Anodized, nylon for $\phi 10$ [0.394in.]              |
| ⑫   | Spring pin               | Alloy steel            | 2    |   |
| ⑬   | Piston yoke              | Aluminum alloy         | 1    | Anodized (chromate treated zinc alloy for $\phi 10$ ) |
| ⑭   | Bearing strip            | Polyethylene           | 2    | For $\phi 40$ [1.575in.], 4 pcs.                      |
| ⑮   | Piston                   | Polyacetal             | 2    |   |
| ⑯   | Piston seal              | Synthetic rubber (NBR) | 2    |   |
| ⑰   | Gasket                   | Rubber contained cork  | 2    |   |
| ⑱   | Hexagon socket setscrew  | Alloy steel            | 2    | Black oxide   |
| ⑲   | Steel ball               | Steel                  | 1    |   |
| ⑳   | End plate L              | Aluminum alloy         | 1    | Anodized  |
| ㉑   | Hexagon socket head bolt | Alloy steel            | 4    | Zinc plated   |
| ㉒   | Attachment holder        | Aluminum alloy         | 2    | Anodized  |
| ㉓   | Hexagon socket head bolt | Alloy steel            | 2    | Zinc plated   |
| ㉔   | Band lock                | Steel                  | 2    | Nickel plated   |

| No. | Parts                           | Materials             | Q'ty | Remarks   |
|-----|---------------------------------|-----------------------|------|---|
| ㉕   | Shock absorber                  | —                     | 2    |   |
| ㉖   | End plate R                     | Aluminum alloy        | 1    | Anodized  |
| ㉗   | Hexagon socket head bolt        | Alloy steel           | 8    | Zinc plated   |
| ㉘   | Magnet strip                    | Rubber magnet         | 2    |   |
| ㉙   | Stopper                         | Steel                 | 1    | Zinc plated   |
| ㉚   | Hexagon socket head bolt        | Alloy steel           | 4    | Zinc plated   |
| ㉛   | Hexagon socket head bolt        | Alloy steel           | 8    | Zinc plated   |
| ㉜   | Hexagon socket head bolt        | Alloy steel           | —    | Zinc plated   |
| ㉝   | Linear guide                    | Steel                 | 1    |   |
| ㉞   | Hexagon socket button head bolt | Stainless steel       | 1    |   |
| ㉟   | Table                           | Aluminum alloy        | 1    | Anodized  |
| ㊱   | Cylinder barrel                 | Aluminum alloy        | 1    | Anodized  |
| ㊲   | Base                            | Aluminum alloy        | 1    | Anodized  |
| ㊳   | Holder nut                      | Steel                 | 2    | Zinc plated   |
| ㊴   | Square nut                      | Steel                 | —    | Zinc plated   |
| ㊵   | Square nut                      | Steel                 | —    | Zinc plated   |
| ㊶   | Sensor magnet                   | Rare earth magnet     | 1    |   |
| ㊷   | Magnet holder                   | Aluminum alloy        | 1    | Anodized  |
| ㊸   | Low head cap screw              | Alloy steel           | 2    | Black oxide for $\phi 10, 16$ , hexagon socket button head bolt |
| ㊹   | Washer                          | Aluminum alloy        | 1    | Anodized  |
| ㊺   | Scraper holder O-ring           | Synthetic rubber (CR) | 1    |   |
| ㊻   | End plate mounting screw        | Steel                 | 2    | Nickel plated   |
| ㊼   | End plate                       | Aluminum alloy        | 2    | Anodized  |
| ㊽   | Heli-sert                       | Stainless steel       | (4)  | Optional  |

## Dimensions of Slit Type Rodless Cylinder ORS10 (mm)

● ORS  ×

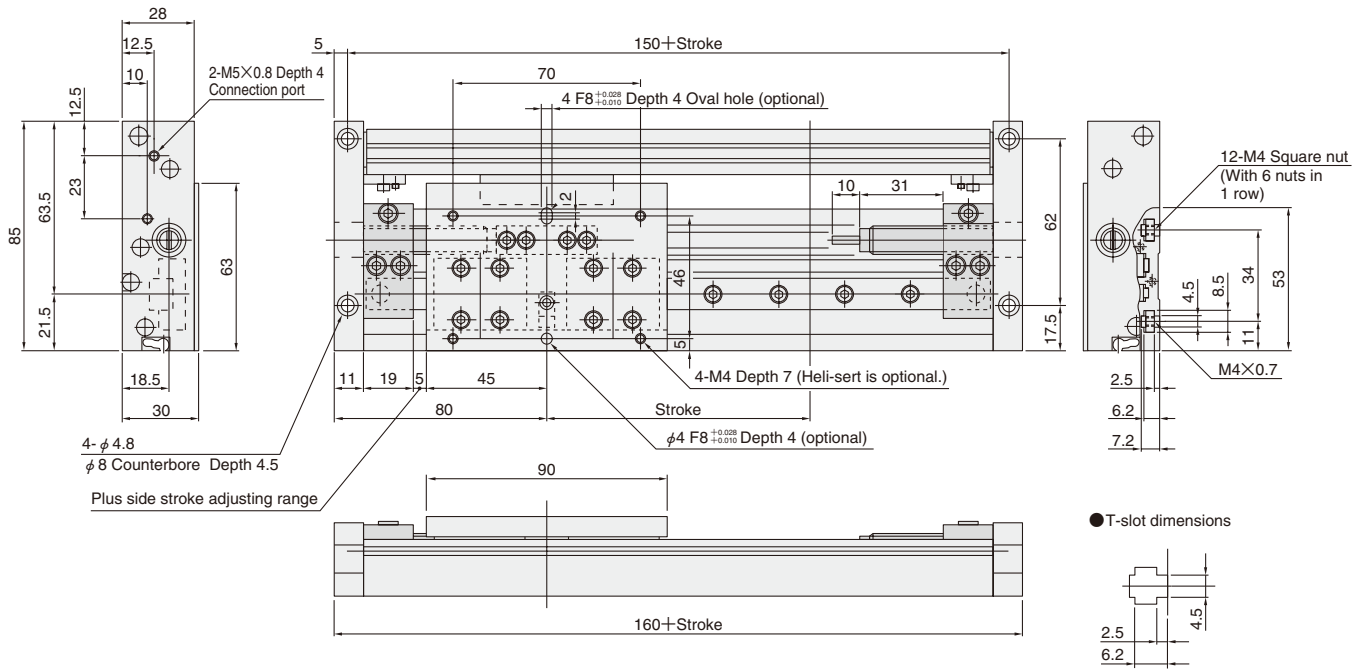

## Dimensions of Shock Absorber (mm)

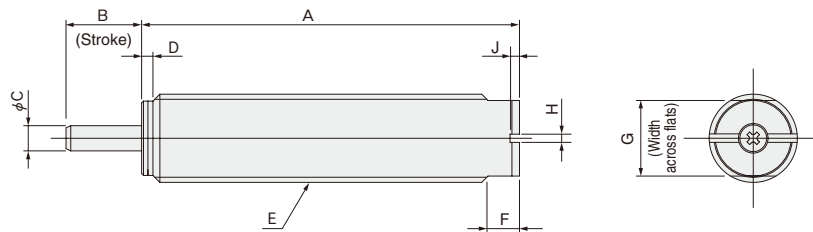

| Model  | Code | A  | B  | C | D | E       | F | G   | H   | J   |
|--|------|----|----|---|---|---------|---|-----|-----|-----|
| KSHJ10X10-01, KSHJ10X10-02 (For $\phi 10$ [0.394in.] and $\phi 16$ [0.630in.]) |      | 50 | 10 | 3 | 2 | M10×1   | 5 | 8.5 | 1.3 | 1.5 |
| KSHJ14X12-01, KSHJ14X12-02 (For $\phi 20$ [0.787in.] and $\phi 25$ [0.984in.]) |      | 60 | 12 | 4 | 2 | M14×1.5 | 5 | 12  | 1.3 | 1.5 |
| KSHJ20X16-01, KSHJ20X16-02 (For $\phi 32$ [1.260in.] and $\phi 40$ [1.575in.]) |      | 77 | 16 | 5 | 3 | M20×1.5 | 7 | 17  | 1.8 | 2   |

SLIT TYPE RODLESS CYLINDERS ORS SERIES/MAGNET TYPE RODLESS CYLINDERS MRS SERIES



# Dimensions of Slit Type Rodless Cylinders ORS16, 20, 25, 32, 40 (mm)

● ORS  Bore size ×  Stroke

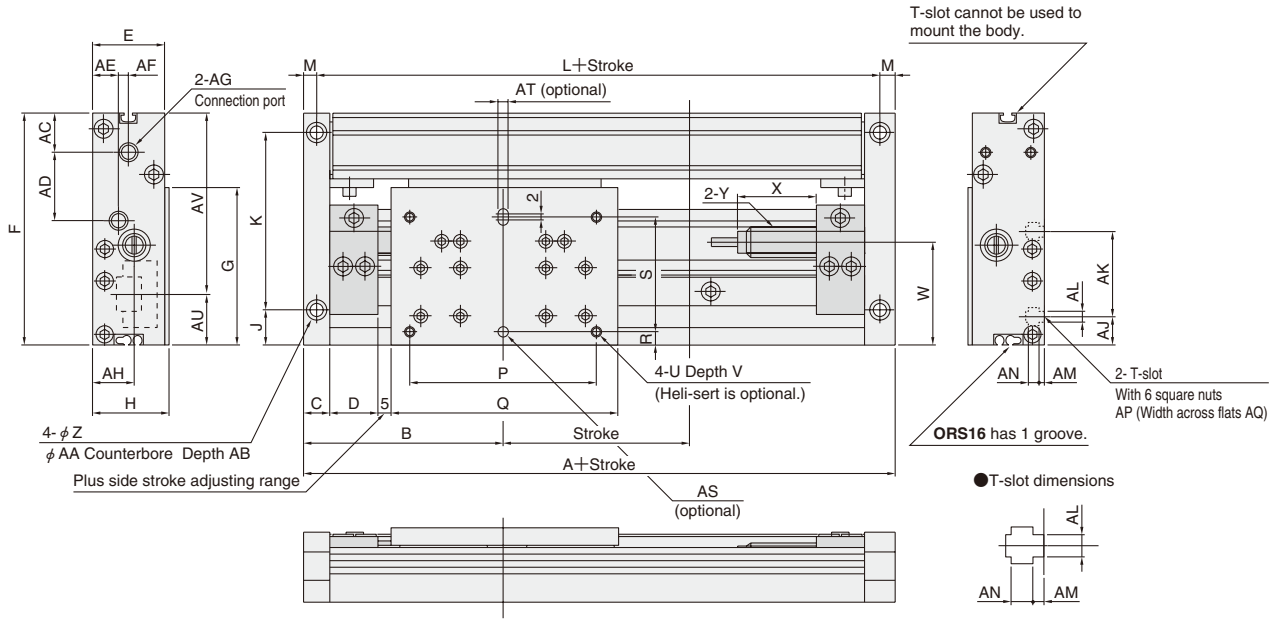

| Bore mm [in.] | Code | A   | B  | C  | D  | E   | F   | G  | H    | J   | K   | L | M   | P   | Q  | R  | S |
|---------------|------|-----|----|----|----|-----|-----|----|------|-----|-----|---|-----|-----|----|----|---|
| 16 [0.630]    | 160  | 80  | 11 | 19 | 28 | 92  | 63  | 30 | 17.5 | 66  | 150 | 5 | 70  | 90  | 5  | 46 |   |
| 20 [0.787]    | 230  | 115 | 14 | 26 | 38 | 132 | 94  | 40 | 19   | 104 | 216 | 7 | 120 | 140 | 7  | 66 |   |
| 25 [0.984]    | 230  | 115 | 14 | 26 | 38 | 137 | 94  | 40 | 19   | 106 | 216 | 7 | 120 | 140 | 7  | 66 |   |
| 32 [1.260]    | 300  | 150 | 17 | 35 | 59 | 164 | 102 | 60 | 20   | 132 | 284 | 8 | 160 | 186 | 10 | 82 |   |
| 40 [1.575]    | 300  | 150 | 17 | 35 | 59 | 173 | 102 | 60 | 20   | 138 | 284 | 8 | 160 | 186 | 10 | 82 |   |

| Bore mm [in.] | Code    | U  | V    | W  | X       | Y   | Z  | AA  | AB   | AC | AD   | AE | AF     | AG |
|---------------|---------|----|------|----|---------|-----|----|-----|------|----|------|----|--------|----|
| 16 [0.630]    | M4×0.7  | 7  | 41.5 | 31 | M10×1   | 4.8 | 8  | 4.5 | 16.5 | 26 | 10   | 3  | M5×0.8 |    |
| 20 [0.787]    | M6×1    | 9  | 61.5 | 34 | M14×1.5 | 7   | 11 | 6.5 | 21   | 37 | 14   | 4  | Rc1/8  |    |
| 25 [0.984]    | M6×1    | 9  | 61.5 | 34 | M14×1.5 | 7   | 11 | 6.5 | 24   | 39 | 14   | 5  | Rc1/8  |    |
| 32 [1.260]    | M8×1.25 | 14 | 65   | 42 | M20×1.5 | 9   | 14 | 8.5 | 32   | 56 | 18.5 | 11 | Rc1/4  |    |
| 40 [1.575]    | M8×1.25 | 14 | 65   | 42 | M20×1.5 | 9   | 14 | 8.5 | 38   | 59 | 18.5 | 11 | Rc1/4  |    |

| Bore mm [in.] | Code | AH | AJ | AK  | AL  | AM  | AN      | AP | AQ            | AS                      | AT   | AU    | AV |
|---------------|------|----|----|-----|-----|-----|---------|----|---------------|-------------------------|------|-------|----|
| 16 [0.630]    | 18.5 | 11 | 34 | 4.5 | 2.5 | 3.7 | M4×0.7  | 8  | φ 4F8 Depth 4 | 4F8 Depth 4 (Oval hole) | 21.5 | 70.5  |    |
| 20 [0.787]    | 24   | 16 | 52 | 6.5 | 3   | 5.5 | M6×1    | 10 | φ 6F8 Depth 6 | 6F8 Depth 6 (Oval hole) | 31.5 | 100.5 |    |
| 25 [0.984]    | 24   | 16 | 52 | 6.5 | 3   | 5.5 | M6×1    | 10 | φ 6F8 Depth 6 | 6F8 Depth 6 (Oval hole) | 31.5 | 105.5 |    |
| 32 [1.260]    | 38.5 | 12 | 60 | 8.5 | 4   | 6.5 | M8×1.25 | 14 | φ 8F8 Depth 8 | 8F8 Depth 8 (Oval hole) | 30   | 134   |    |
| 40 [1.575]    | 38.5 | 12 | 60 | 8.5 | 4   | 6.5 | M8×1.25 | 14 | φ 8F8 Depth 8 | 8F8 Depth 8 (Oval hole) | 30   | 143   |    |

# SENSOR SWITCHES

Solid State Type, Reed Switch Type

## Symbol

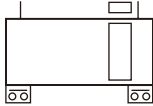

## Order Codes

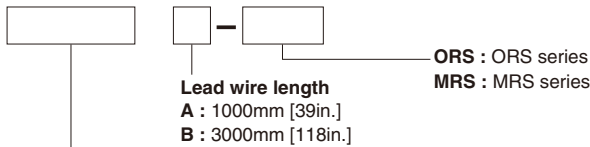

### Sensor switch

**ZE135** : Solid state type with indicator lamp DC10V~28V Horizontal lead wire  
**ZE101** : Reed switch type without indicator lamp DC5V~28V Horizontal lead wire  
 AC85~115V

**ZE155** : Solid state type with indicator lamp DC4.5V~28V Horizontal lead wire  
**ZE102** : Reed switch type with indicator lamp DC10V~28V Horizontal lead wire  
 AC85~115V

● For details of sensor switches, see p.1544.

## Moving Sensor Switch

Loosening the sensor switch's mounting screw allows the sensor switch to be moved along the switch mounting groove on the base.

It is possible to insert the lead wire into the groove.

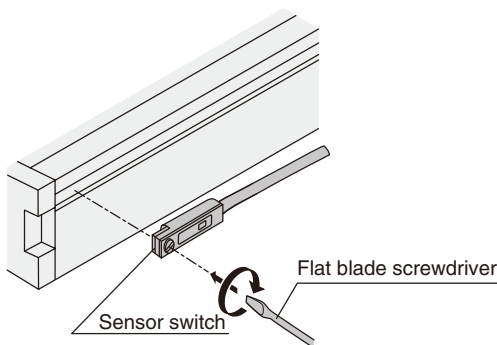

● Tighten the mounting screw with a tightening torque of 20~30N·cm [1.8~2.7in·lbf].

## Mounting Location of End of Stroke Detection Sensor Switch

mm [in.]

When the sensor switch is mounted in the locations shown below, the magnet comes to the maximum sensing location of the sensor switch at the end of the stroke.

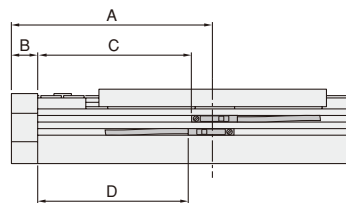

### ● Reed switch type (ZE101, ZE102)

| Model               | A           | B          | C           | D             |
|---------------------|-------------|------------|-------------|---------------|
| <b>ORS10, MRS10</b> | 80 [3.150]  | 11 [0.433] | 59 [2.323]  | 56.5 [2.224]  |
| <b>ORS16, MRS16</b> | 80 [3.150]  | 11 [0.433] | 59 [2.323]  | 56.5 [2.224]  |
| <b>ORS20, MRS20</b> | 115 [4.528] | 14 [0.551] | 91 [3.583]  | 88.5 [3.484]  |
| <b>ORS25, MRS25</b> | 115 [4.528] | 14 [0.551] | 91 [3.583]  | 88.5 [3.484]  |
| <b>ORS32, MRS32</b> | 150 [5.906] | 17 [0.669] | 123 [4.843] | 120.5 [4.744] |
| <b>ORS40, MRS40</b> | 150 [5.906] | 17 [0.669] | 123 [4.843] | 120.5 [4.744] |

### ● Solid state type (ZE135, ZE155)

| Model               | A           | B          | C           | D             |
|---------------------|-------------|------------|-------------|---------------|
| <b>ORS10, MRS10</b> | 80 [3.150]  | 11 [0.433] | 63 [2.480]  | 59.5 [2.343]  |
| <b>ORS16, MRS16</b> | 80 [3.150]  | 11 [0.433] | 63 [2.480]  | 59.5 [2.343]  |
| <b>ORS20, MRS20</b> | 115 [4.528] | 14 [0.551] | 95 [3.740]  | 91.5 [3.602]  |
| <b>ORS25, MRS25</b> | 115 [4.528] | 14 [0.551] | 95 [3.740]  | 91.5 [3.602]  |
| <b>ORS32, MRS32</b> | 150 [5.906] | 17 [0.669] | 127 [5.000] | 123.5 [4.862] |
| <b>ORS40, MRS40</b> | 150 [5.906] | 17 [0.669] | 127 [5.000] | 123.5 [4.862] |

# Handling Instructions and Precautions



## Selection and Mounting

### Allowable load and moment

Although the rodless cylinders **ORS**, **MRS** series can be used with directly applying loads, make sure that the load and moment do not exceed the values in the table below.

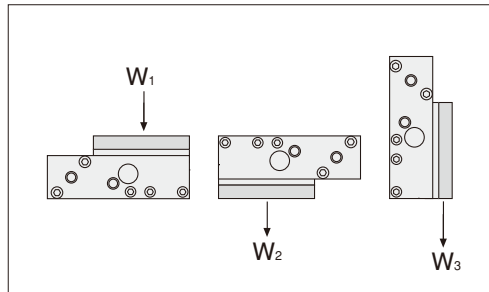
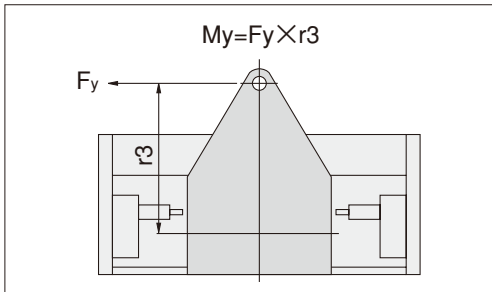
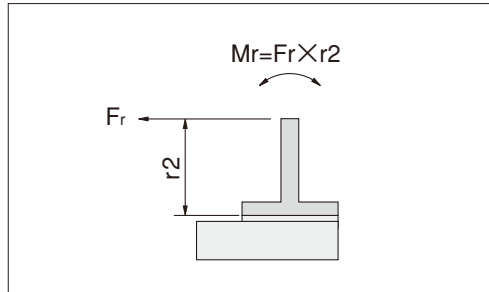
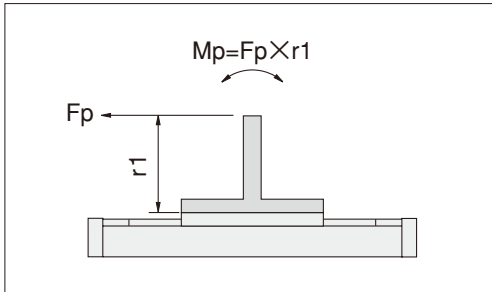

Pitching moment :  $M_p = F_p \times r_1$  (N·m)

Rolling moment :  $M_r = F_r \times r_2$  (N·m)

Yawing moment :  $M_y = F_y \times r_3$  (N·m)

Maximum load capacity :  $W_1, W_2, W_3$  (N)

| Model               | Moment and Max. load | $M_p$<br>N·m [ft·lbf] | $M_r$<br>N·m [ft·lbf] | $M_y$<br>N·m [ft·lbf] | $W_1$<br>N [lbf.] | $W_2$<br>N [lbf.] | $W_3$<br>N [lbf.] |
|---------------------|----------------------|-----------------------|-----------------------|-----------------------|-------------------|-------------------|-------------------|
| <b>ORS10, MRS10</b> |                      | 6 [4.4]               | 5 [3.7]               | 6 [4.4]               |                   | 130 [29.2]        |                   |
| <b>ORS16, MRS16</b> |                      | 6 [4.4]               | 5 [3.7]               | 6 [4.4]               |                   | 130 [29.2]        |                   |
| <b>ORS20, MRS20</b> |                      | 26 [19.2]             | 25 [18.4]             | 25 [18.4]             |                   | 300 [67.4]        |                   |
| <b>ORS25, MRS25</b> |                      | 26 [19.2]             | 25 [18.4]             | 25 [18.4]             |                   | 300 [67.4]        |                   |
| <b>ORS32, MRS32</b> |                      | 60 [44.3]             | 50 [36.9]             | 60 [44.3]             |                   | 600 [135]         |                   |
| <b>ORS40, MRS40</b> |                      | 60 [44.3]             | 50 [36.9]             | 60 [44.3]             |                   | 600 [135]         |                   |

- Cautions:**
- The moment including the inertial force generated when the load is moved or stopped must not exceed the values in the above table. For the load and speed, keep within the range of the shock absorber capacity graph.
  - In the rodless cylinders **ORS** series, the T-slot on the cylinder barrel is not suitable for mounting. Since an insufficiently secured cylinder by using the above T-slot during operation could result in damage, always use an end plate mounting hole or a square nut in the T-slot on the bottom to mount the cylinder in place.

### Shock absorber absorption capacity

Shock absorbers are standard equipment for the entire rodless cylinders **ORS**, **MRS** series. Find the figures for the absorption mass and impact speed from the impact speed graph, which then should be within the ranges of the "Shock absorber capacity graph" below. It cannot be used with speeds in excess of the maximum operating speeds of 1000mm/s [39.4in./sec.] or 2000mm/s [78.7in./sec.].

#### Impact speed graph (Horizontal use, at air pressure of 0.5MPa)

The graph below shows the table's required time to reach the end of the stroke, at impact speeds of 1000mm/s [39.4in./sec.] or 2000mm/s [78.7in./sec.], for each stroke.

In operation, set the time in above area of the graph's curve.

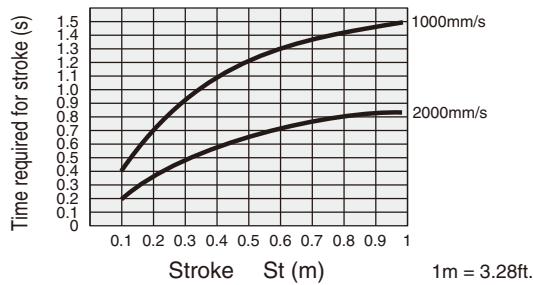

#### Shock absorber capacity graph

(Horizontal operation, at air pressure of 0.5MPa)

The "mass" in the graph refers to the total mass carried by the **ORS** and **MRS** series. "Impact speed" refers to the speed immediately before striking the shock absorber. Note that this is not the same as "average speed (cylinder stroke/time required)."

#### For $\phi 10$ [0.394in.] and $\phi 16$ [0.630in.]

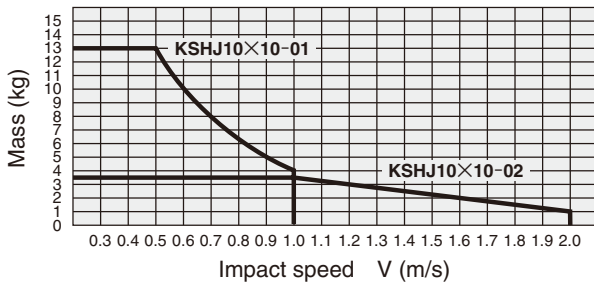

#### For $\phi 20$ [0.787in.] and $\phi 25$ [0.984in.]

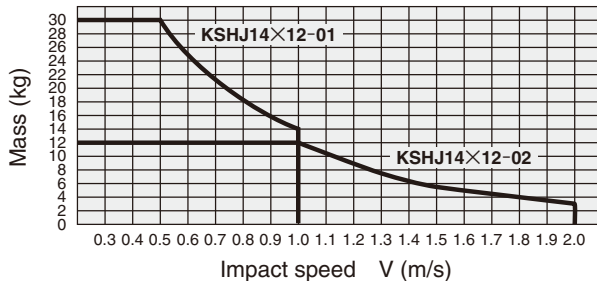

#### For $\phi 32$ [1.260in.] and $\phi 40$ [1.575in.]

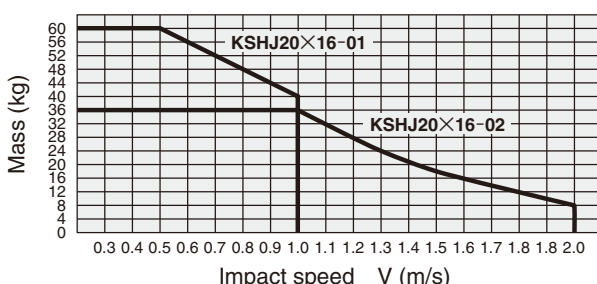

1kg = 2.205lb. 1m/s = 3.28ft./sec.

### Shock absorber stroke adjustment

In the rodless cylinders **ORS** and **MRS** series, stroke adjustment by the shock absorber is easy for entire strokes.

- ① Loosen the holder mounting bolts, and move the attachment holder to determine the rough position.
- ② Press the holder against the guides such that the shock absorber contacts the impact surface of the table at right angles, and then tighten and secure it in place with the holder mounting bolts.
- ③ Next, loosen the shock absorber mounting bolt.
- ④ Insert a flat blade screwdriver into the shock absorber's straight groove to finely adjust the position by rotating it so that it provides the required stopping position of the table.
- ⑤ Finally, tighten and secure the shock absorber mounting bolt, and complete the operation.

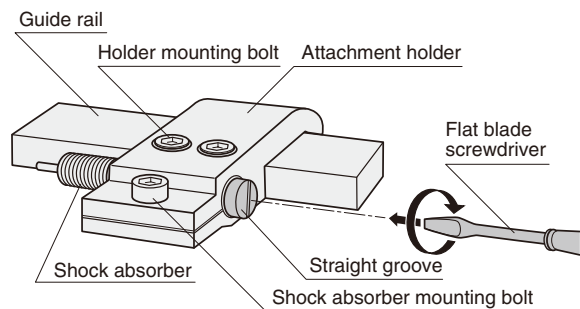

#### Approximate tightening torque for holder mounting bolt

| Bore size<br>mm [in.] | Tightening torque<br>N·cm [in·lbf] | Allen wrench size<br>mm [in.] |
|-----------------------|------------------------------------|-------------------------------|
| 10,16 [0.394,0.630]   | 140 [12.4]                         | 3 [0.118]                     |
| 20,25 [0.787,0.984]   | 450 [39.8]                         | 5 [0.197]                     |
| 32,40 [1.260,1.575]   | 1350 [119.5]                       | 6 [0.236]                     |

Remark: For securing the shock absorber holder in place, use the above values to tighten the bolt.

- Cautions:**
1. Adjust it so that the stopper on the table and the shock absorber make full contact.
  2. Use the shock absorber within the range of the capacity of the shock absorber (range of the capacity graph). Note that the absorption energy of the shock absorber is different in a low-speed range than that in a high-speed range.
  3. The maximum impact speed of the shock absorber will vary depending on the shock absorber. Moreover, since impact speed and average speed are not the same, use only after checking the shock absorber's impact speed.
  4. Do not use the shock absorber in a place subject to dripping water or oil, or to large amount of dust. If using it in these places, install a cover, etc. so that the water or oil drops do not drip it directly. Otherwise, it could lead to improper operation and may decrease the absorption energy.
  5. Do not loosen the small screw on the rear end of the shock absorber. The oil inside will leak out which will fail the function of the shock absorber.
  6. To ensure that the table is not in contact with the attachment holder, always adjust the location of the shock absorber so that a clearance exists between the table and the attachment holder. Contact of anything other than the absorber when stopping could result in damage to the cylinder.
  7. Do not install other shock absorbers for this product without our permission. Since our shock absorber's characteristics are different from those of other shock absorbers, use of other shock absorbers could cause damage to the cylinder.

# Handling Instructions and Precautions

## Mounting with T-slot

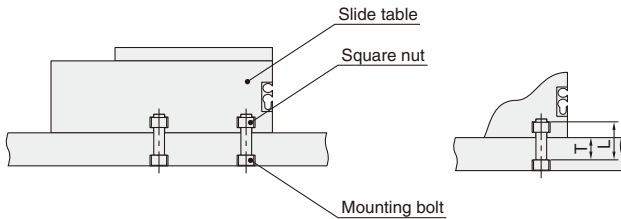

### ● Tightening torque

N·cm [in·lbf]

| Type              | ORS10,16<br>MRS10,16 | ORS20,25<br>MRS20,25 | ORS32,40<br>MRS32,40 |
|-------------------|----------------------|----------------------|----------------------|
| Tightening torque | 140 [12.4]<br>(M4)   | 450 [39.8]<br>(M6)   | 1350 [119.5]<br>(M8) |

### ● Screw length L

mm [in.]

| Type | ORS10,16<br>MRS10,16 | ORS20,25<br>MRS20,25 | ORS32,40<br>MRS32,40 |
|------|----------------------|----------------------|----------------------|
| L    | M4<br>T + 6 [0.236]  | M6<br>T + 8 [0.315]  | M8<br>T + 10 [0.394] |

## Mounting

1. While any mounting direction in the rodless cylinders **ORS**, **MRS** series is allowed, mount the slider so that it faces downward or protect it with a cover, etc., when mounting in locations subject to dripping water or oil, etc., or to large amounts of dust. Mounting as the seal band faces downward is particularly effective for the **ORS** series.
2. Avoid any electric welding either during or after mounting the rodless cylinders **ORS**, **MRS** series. Flows of welding current to the cylinder could generate arcs that result in damage or depositions to the cylinder.
3. Since the magnet type rodless cylinders **MRS** series has strong magnets built into the cylinder body, do not use in locations subject to cutting oil or metal chips that contain magnetized materials.
4. Be careful to avoid making scratches or dents, etc., on the cylinder tube/barrel and guide.
5. If external forces exceeding the magnet retaining force cause the slider and piston to become misaligned or separated, make the piston return to the end of the stroke and then apply an external force to the slider to restore it to the correct position.
6. If using in locations where the cylinder tube/barrel and guide can easily become smeared, clean the cylinder tube/barrel and guide periodically.  
After cleaning, always apply lubrication to the cylinder tube and guide surfaces.
7. Avoid using the rodless cylinders **ORS**, **MRS** series in combination with linear ball bearings and other external guides.

**Caution:** Do not apply a strong shock to the slit portion of the cylinder barrel.

## Intermediate stopping control

1. Since for structural reasons external air leakage is inevitable for the **ORS** series, use of all port block (closed center) 3-position valves, etc., for intermediate stop control could result in failure to maintain the stopping position, and the piston speed could not be controlled when restarting. We recommend, therefore, the installation of double-sided pressure control circuits that use PAB-connection (pressure center) 3-position valves, etc.  
For intermediate stopping under constant loads, such as vertical mountings, consult us.
2. For the **MRS** series, hold the pressure at 0.55MPa [80psi.] or less when used with external stoppers, etc., for intermediate stroke stopping. Use at higher pressures may cause the piston to misalign.

**Calculation of impact energy**

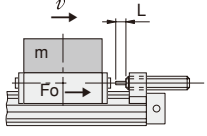
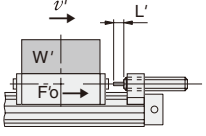
| Horizontal impact   |   |
|---|---|
|  |  |
| $E = E_1 + E_2$ $= \frac{m \cdot v^2}{2} + F_0 \cdot L$                           | $E' = E'_1 + E'_2$ $= \frac{W' \cdot v'^2}{2g'} + F'_0 \cdot L'$                  |

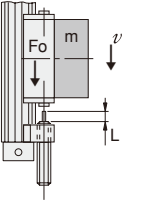
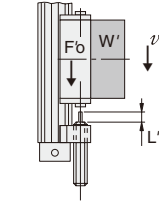
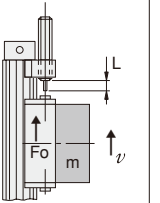
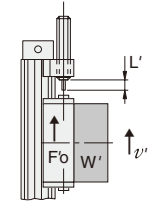
| Vertical impact <small>Note 1</small>  |   |  |   |
|--|---|--|---|
| When descending <small>Note 2</small>  |   | When ascending   |   |
|  |     |  |     |
| $E = E_1 + E_2 + E_3$ $= \frac{m \cdot v^2}{2} + F_0 \cdot L + m \cdot g \cdot L$  | $E' = E'_1 + E'_2 + E'_3$ $= \frac{W' \cdot v'^2}{2g'} + F'_0 \cdot L' + W' \cdot L'$ | $E = E_1 + E_2 - E_3$ $= \frac{m \cdot v^2}{2} + F_0 \cdot L - m \cdot g \cdot L$  | $E' = E'_1 + E'_2 - E'_3$ $= \frac{W' \cdot v'^2}{2g'} + F'_0 \cdot L' - W' \cdot L'$ |

Note 1: For impact on incline, E<sub>3</sub> becomes E<sub>3</sub>' = m · g · L · sin θ .

Note 1: For impact on incline, E<sub>3</sub>' becomes E<sub>3</sub>' = W' · L' · sin θ .

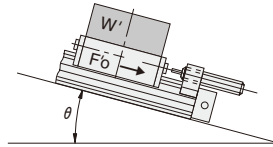
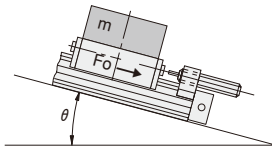

Note 2: When descending, the operating air pressure: P, should be lower than when ascending, because heavier loads can be carried.

- E : Total impact energy ... [J]
- E<sub>1</sub> : Kinetic energy ...  $\frac{m \cdot v^2}{2}$  [J]
- E<sub>2</sub> : Additional energy by cylinder thrust ... F<sub>0</sub> · L [J]
- E<sub>3</sub> : Additional energy by load mass ... m · g · L [J]
- m : Load mass [kg]
- v : Impact speed [m/s]
- g : Gravity acceleration 9.8 [m/s<sup>2</sup>]
- F<sub>0</sub> : Cylinder thrust ...  $= \frac{\pi}{4} \cdot D^2 \cdot P$  [N]
- [D: Cylinder bore (mm) P: Operating air pressure (MPa)]
- L : Absorbing stroke of shock absorber [m]

Note 2: When descending, the operating air pressure: P', should be lower than when ascending, because heavier loads can be carried.

- E' : Total impact energy ... [ft·lbf]
- E'<sub>1</sub> : Kinetic energy ...  $\frac{W' \cdot v'^2}{2g'}$  [ft·lbf]
- E'<sub>2</sub> : Additional energy by cylinder thrust ... F'<sub>0</sub> · L' [ft·lbf]
- E'<sub>3</sub> : Additional energy by load weight ... W' · L' [ft·lbf]
- W' : Load weight [lbf]
- v' : Impact speed [ft./sec.]
- g' : Gravity acceleration 32.2 [ft./sec.]
- F'<sub>0</sub> : Cylinder thrust ...  $= \frac{\pi}{4} \cdot D'^2 \cdot P'$  [lbf]
- [D': Cylinder bore [in.] P': Operating air pressure [psi.]
- L' : Absorbing stroke of shock absorber [ft.]

## Special Rodless Cylinders in ORS and MRS Series

For the rodless cylinders **ORS** and **MRS** series, we have targeted certain special models that have proven to be particularly popular as semi-standard products.

To order, enter codes in parentheses ( ) at the end of the order code.

As we expand our special product range, we hope you will continue to incorporate new models into your work.

For detailed specifications, dimensions, and delivery schedules, consult us.

### 1. Clean room-compatible grease specification (-1002W)

#### For MRS series only

Uses a low-volatility, low particle generation grease. The linear guide uses a standard grease, however.

### 2. Low-speed and speed-variable specification (-1003W)

Effective for operations that involve repeated stops and starts, and for constant low-speed operations.

**Operating speed range** 20~100mm/s [0.8~3.9in./sec.]

### 3. Simplified clean room specification (-1014W)

#### For MRS series only

The linear guide is Raydent-treated, while the bolts and screws are stainless steel or nickel-plated. Moreover, the grease used is a low particle generation grease. The items are not packaged in the clean rooms, however. And the shock absorber is not available for the clean room specification.

### 4. Lateral piping block specification (-3W)

Can be used for piping in lateral directions.

※ With the exception of a longer total length, other specifications are the same as the standard item.

### 5. Reverse piping directions specification (-4W)

Since piping directions in the ORS and MRS series are set, use this specification for piping in the reverse direction.

※ Other specifications are the same as the standard item.

**Order example :**  
**For reverse piping specification**

● **ORSP16 × 300 - KL - 4W**

Note: These special specifications may vary from standard items in delivery, prices, dimensions, life cycles, etc. Confirm us the details before ordering.

Moreover, consult us about similar available settings in other rodless cylinder series.