

Static Electricity Removing Unit Ionizer

Wide Area Fan Type Overhead Fan Type

Can eliminate static charge over an extensive range



Wide area fan type



Overhead fan type



Static Electricity Removing Unit Ionizer Wide Area Fan Type

Features

- Air supply is not required, and two types can be chosen depending on the installation location and application.
- Can eliminate static charge over an extensive range.
- Exhibits stable, long-term performance in eliminating static charge thanks to a newly developed AC (200 Hz) format.
- Louver and discharge needle unit can be removed by one touch, without any tools.
- Airflow can be controlled by adjusting the airflow volume.
- Safety is ensured by the detection of abnormal electrical discharge and overcurrent.



DTY-FA01
(Two fan motors type)



DTY-FA02
(Three fan motors type)

● DTY-FA01

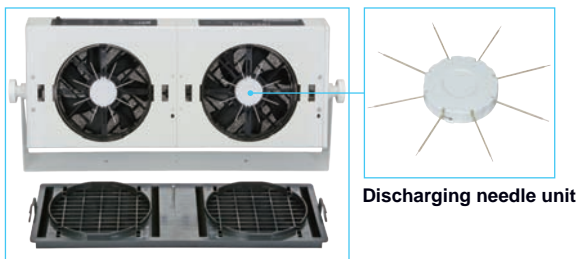
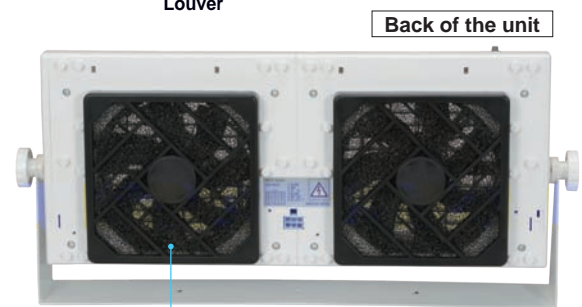
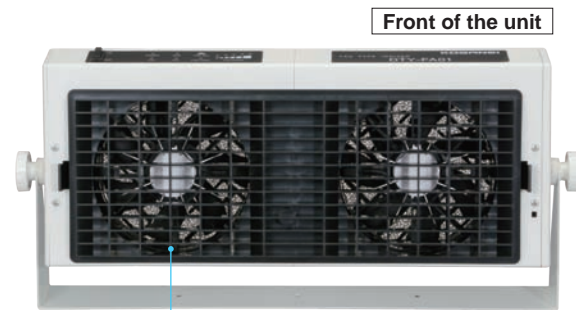
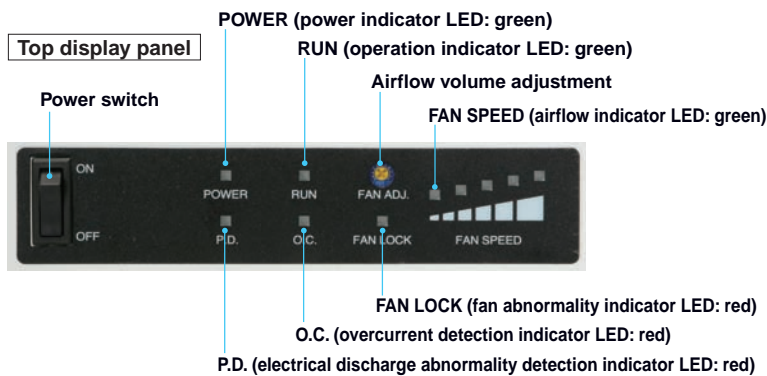

● DTY-FA02

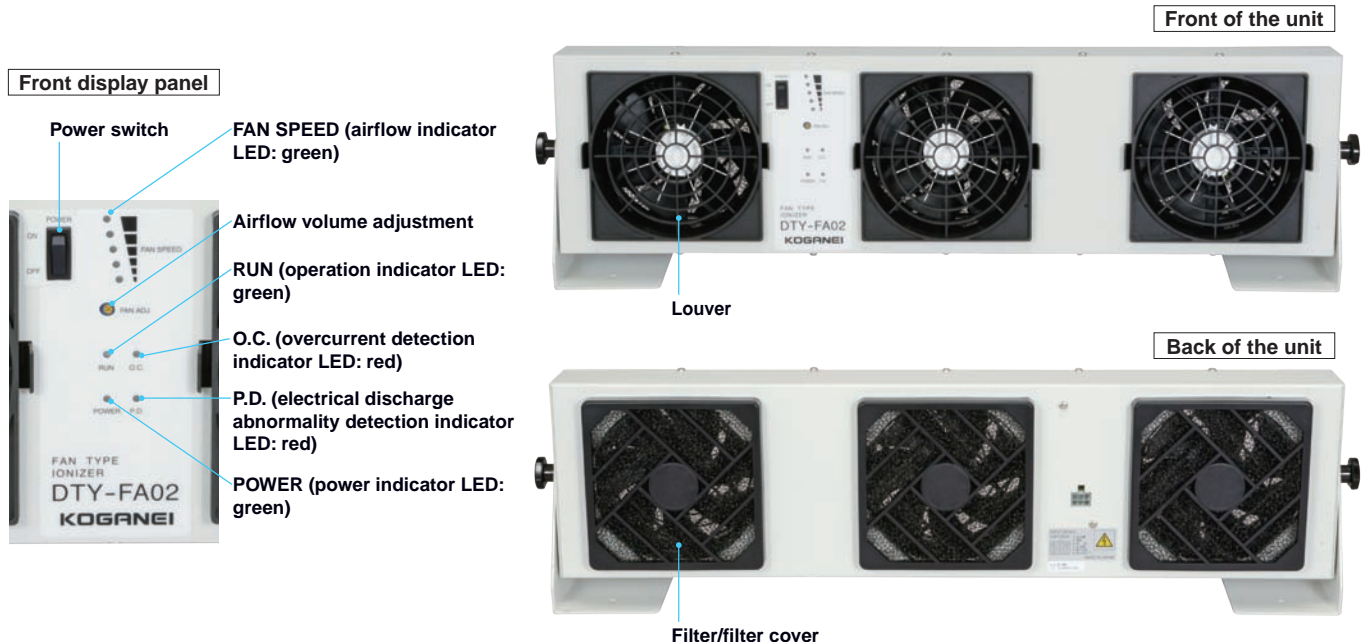

Static Electricity Removing Unit Ionizer Overhead Fan Type

Features

- Overhead fan type ionizer for which air supply is not required.
- Can eliminate static charge over an extensive range.
- Exhibits stable, long-term performance in eliminating static charge thanks to a newly developed AC (200 Hz) format.
- Louver and discharge needle unit can be removed by one touch, without any tools.
- Airflow can be controlled with the air flow rate adjusting knob.
- Safety is ensured by the detection of abnormal electrical discharge.



DTY-HA01

● DTY-HA01



Louver

Outlet side



Filter/filter cover

Back side

φ5.5 [0.217] mounting hole

φ12 [0.472] mounting hole



Power input connector

Power switch

Display panel

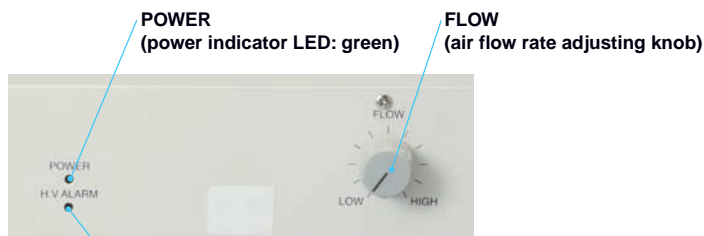

POWER (power indicator LED: green)

FLOW (air flow rate adjusting knob)

H.V. ALARM (high voltage abnormality indicator LED: red)

Graphs of static charge removal characteristics/ranges of static charge removal

Wide area fan type

DTY-FA01

1 mm = 0.0394 in

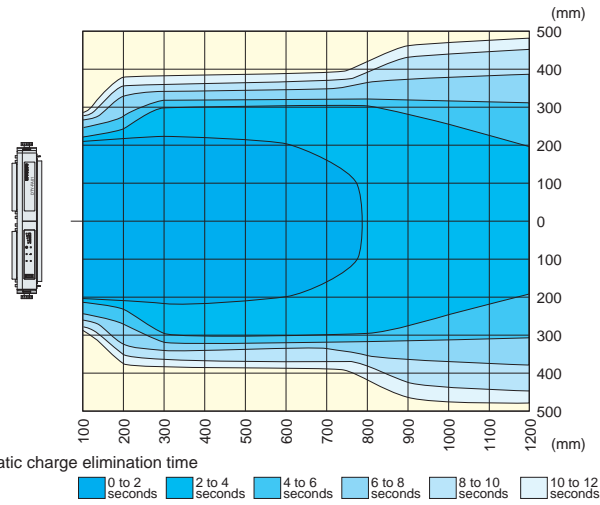
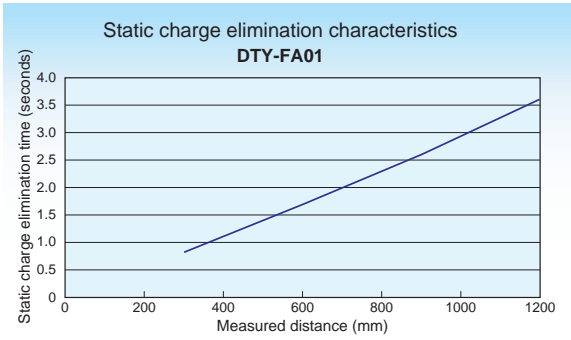

Wide area fan type

DTY-FA02

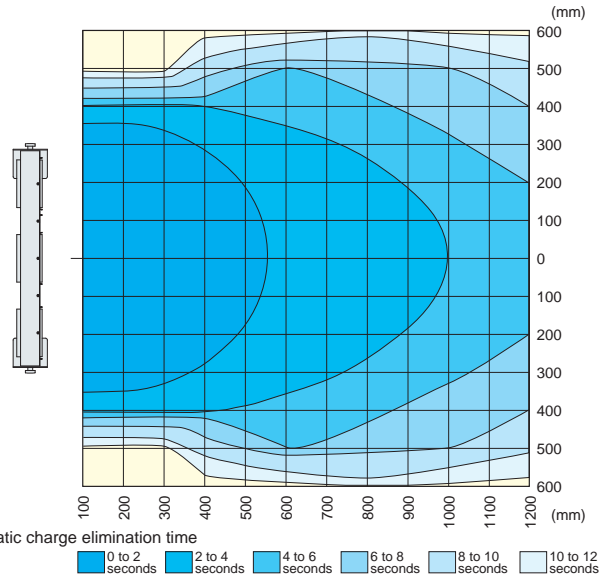
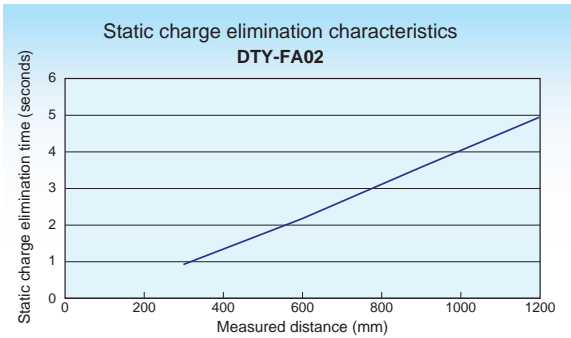

Overhead fan type

DTY-HA01

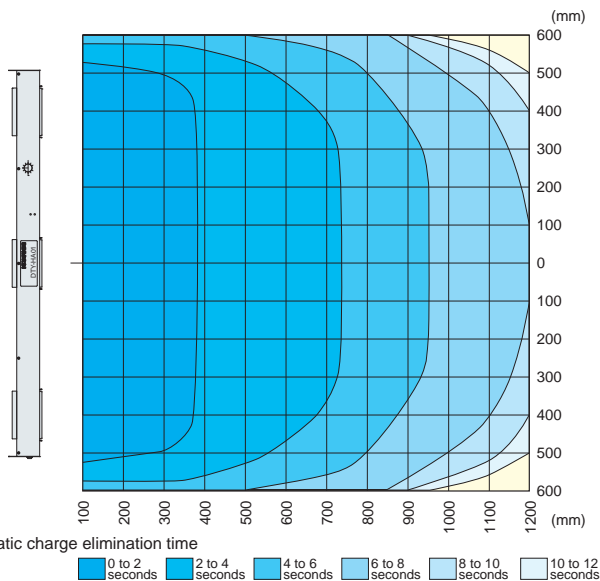
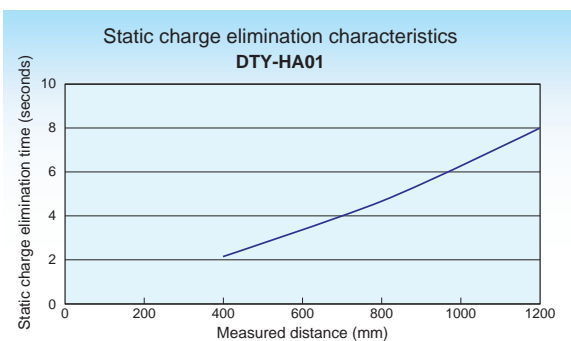

- Note 1: The static charge removing characteristics are measured by in-house test standard using the charged plate monitor of 20 pF, 150 mm [5.9 in].
 2: The static charge removal time means decaying time from ± 1000 V to ± 100 V at the max. flow rate.
 3: These values are measured values and not guaranteed values.
 4: Static charge elimination characteristics are values for the center of the unit.

Specifications

Wide area fan type

Item	Model	DTY-FA01	DTY-FA02
Input voltage		24 VDC ±5%	
Consumption current	A	1.0	1.25
Output voltage	kV	±7.5	
Indicator LED	POWER (green)	Lit when power is on	
	RUN (green)	Lit when high voltages are applied to electrodes	
	FAN SPEED (green)	Displayed as 5 levels of fan airflow	
	P.D. (red)	Lit when there is an electrical discharge abnormality (RUN LED turns off)	
	O.C. (red)	Lit when there is an overcurrent in the high voltage circuit (RUN LED turns off)	
	FAN LOCK (red)	Lit when there is a fan abnormality	—
Output		Contact output when red LED is lit (contact b, max. of 24 VDC, 50 mA)	
Ion balance ^{Note 1}	V	±5	
Static charge elimination time ^{Note 1}	sec.	1.0 or less	1.5 or less
Amount of ozone generated ^{Note 2}	ppm	0.006 or less	
Fan power	Maximum airflow m ³ /min [ft ³ /min]	3.2 × 2 fan [112.992 × 2 fan]	3.2 × 3 fan [112.992 × 3 fan]
	Control	Smooth control with airflow volume adjustment	
External dimensions ^{Note 3}	mm [in]	370 [14.6] (W) × 159 [6.3] (H) × 78.5 [3.091] (D)	566 [22.3] (W) × 146 [5.7] (H) × 69.5 [2.736] (D)
Weight ^{Note 4}	kg [lb]	1.7 [3.748]	3.1 [6.834]
Usage environment		Indoor 0 to 40°C [0 to 104°F], 15 to 85% RH (with no condensation)	
Accessories		Installation manual, AC adaptor, output signal lead wires (set of 2), cleaning brush for discharge needle 1 bracket set (DTY-FA01 mounted on unit, DTY-FA02 included)	

Note 1: 300 mm [11.8 in] from the center of the fan outlet, at maximum flow rate.

2: 150 mm [5.9 in] from the center of the fan outlet, at maximum flow rate.

3: When protrusions and brackets removed.

4: Including brackets.

Remark: Ion balance and static charge removal time were measured by in-house test standard. Contact us for more detail.

Overhead fan type

Item	Model	DTY-HA01
Input voltage		100 to 240 VAC 50/60 Hz
Power consumption	VA	42
Output voltage	kV	±7.5
Indicator LED	POWER (green)	Lit when power is on
	H.V. ALARM (red)	Lit when there is a high voltage abnormality
Ion balance ^{Note 1}	V	±10
Static charge elimination time ^{Note 1}	sec.	4.0 or less
Amount of ozone generated ^{Note 2}	ppm	0.005 or less
Fan power	Maximum airflow m ³ /min [ft ³ /min]	4.0 × 3 fan [141.240 × 3 fan]
	Control	Smooth control with air flow rate adjusting knob
External dimensions ^{Note 3}	mm [in]	1020 [40] (W) × 60.5 [2.382] (H) × 150 [5.9] (D)
Weight	kg [lb]	5.0 [11.023]
Usage environment		Indoor 0 to 40°C [0 to 104°F], 15 to 85% RH (with no condensation)
Accessories		Installation manual, AC cable, cleaning brush for discharge needle

Note 1: 450 mm [17.7 in] from the center of the fan outlet, at maximum flow rate.

2: 150 mm [5.9 in] from the center of the fan outlet, at maximum flow rate.

3: When protrusions removed.

Remark: Ion balance and static charge removal time were measured by in-house test standard. Contact us for more detail.

Order codes

Wide area fan type

Unit

DTY-FA01 (two fan motors type)



* Output signal lead wires (included)



AC adaptor (included)

DTY-FA02 (three fan motors type)



* Output signal lead wires (included)



AC adaptor (included)

Options (sold separately)

- Replacement discharge needle unit (quantity: 1)
DTY-ZEM-FA



- Replacement filter (quantity: set of 6)
DTY-ZFR-FA

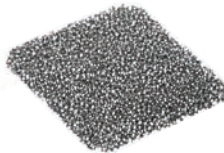

- Filter cover (quantity: 1)
DTY-ZFRC-FA

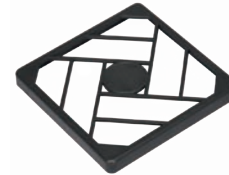

- Louver (quantity: 1)
DTY-ZL-FA01 (for DTY-FA01)
DTY-ZL-FA02 (for DTY-FA02)

- Bracket (1 set)
DTY-ZBK-FA01 (for DTY-FA01)
* 2 knob bolts included
DTY-ZBK-FA02 (for DTY-FA02)
* 2 knob bolts, 2 rubber gaskets included

- AC adaptor
DTY-ZPS3
Rated
Input: 100 to 240 VAC
50/60 Hz 1.2 A
Output: 24 VDC 2.1 A



- Output signal lead wires (2 m [6.562 ft])
DTY-ZSL-FA

Overhead fan type

Unit

DTY-HA01 (three fan motors, overhead fan type)



AC cable (included)

Options (sold separately)

- Replacement discharge needle unit (quantity: 1)
DTY-ZEM-FA



- Replacement filter (quantity: set of 6)
DTY-ZFR-FA

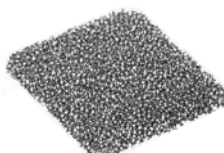

- Filter cover (quantity: 1)
DTY-ZFRC-FA



- Louver (quantity: 1)
DTY-ZL-FA02

Dimensions (mm [in])

Wide area fan type

●DTY-FA01

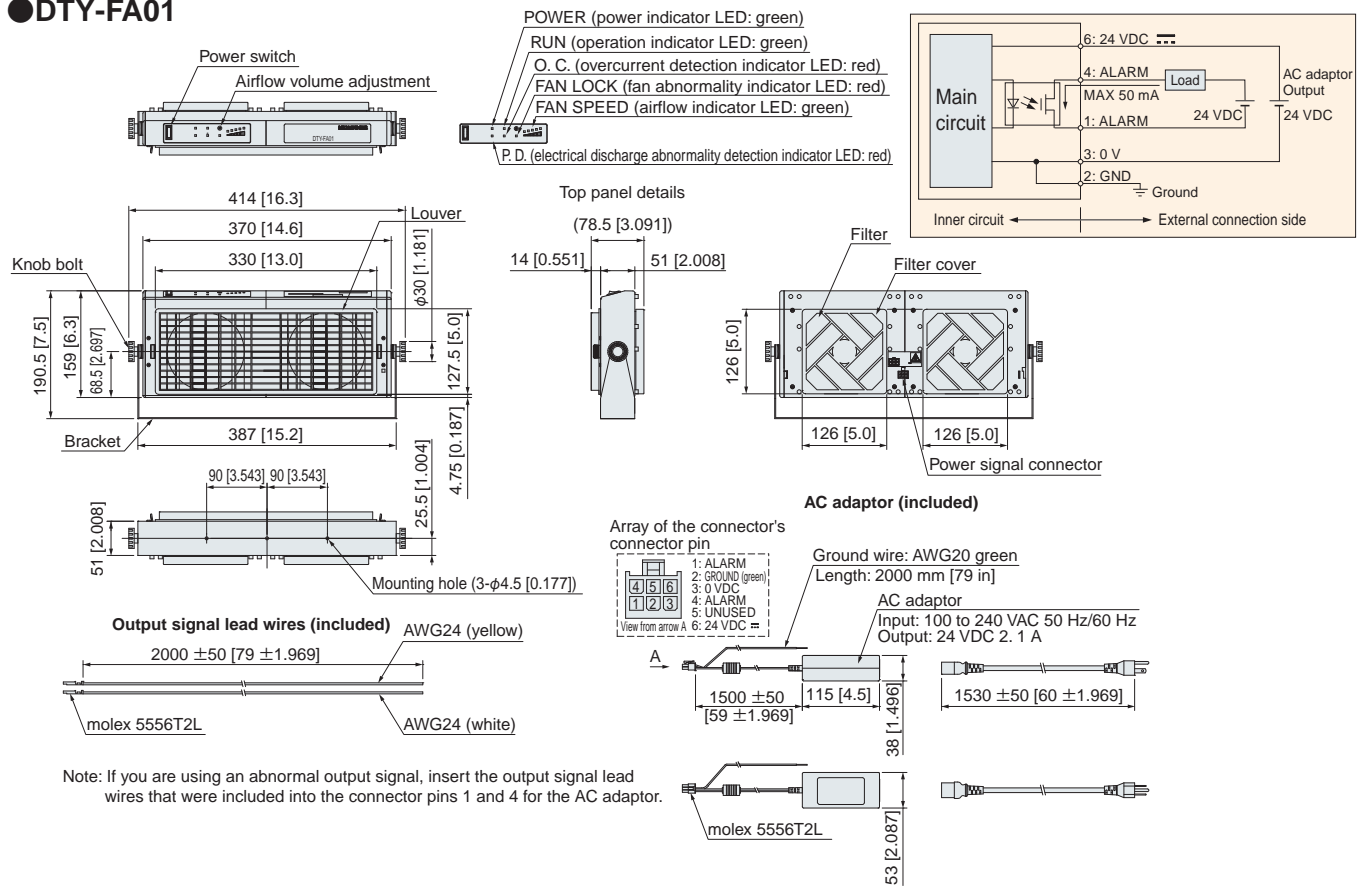

●DTY-FA02

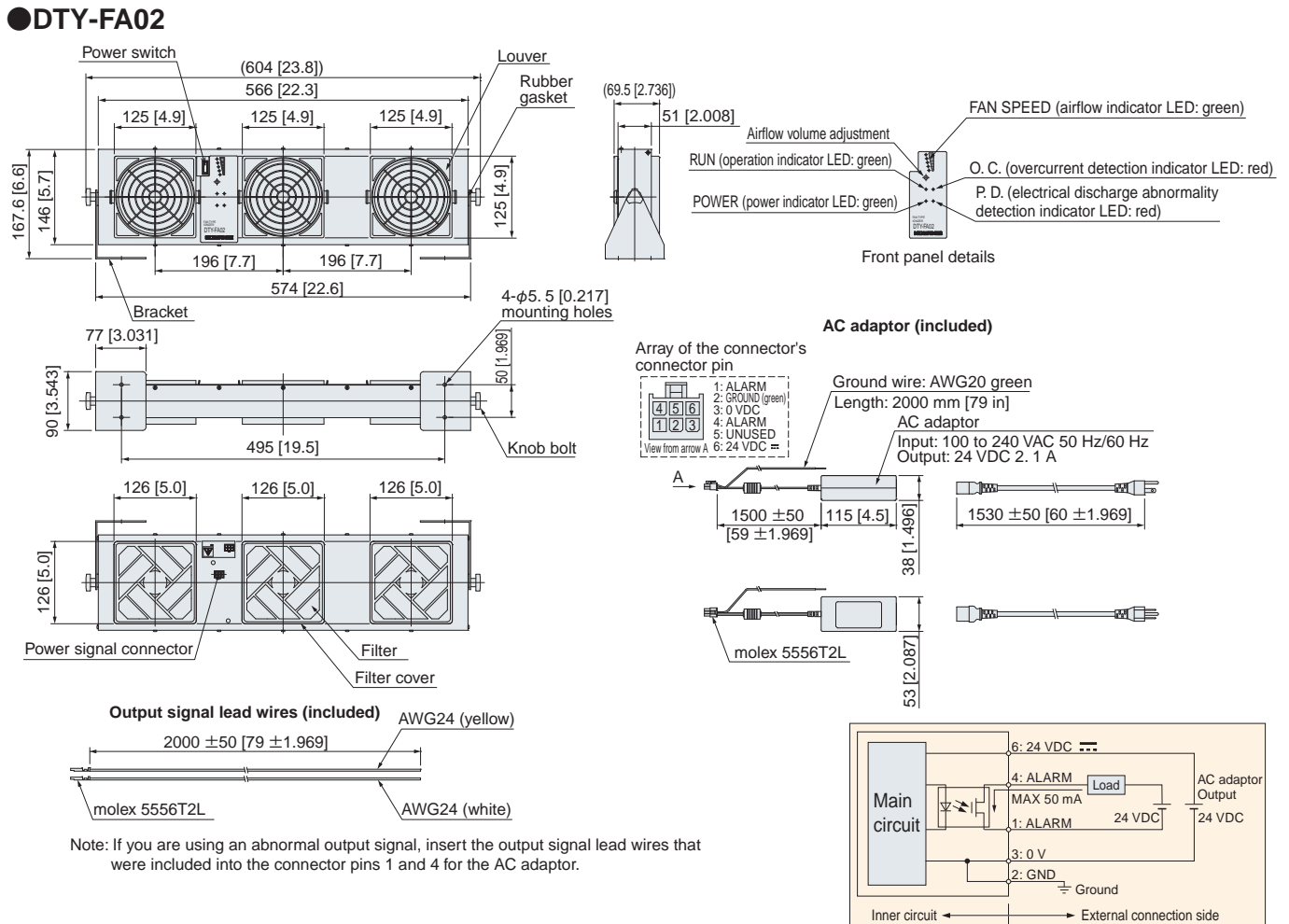

Dimensions (mm [in])

Overhead fan type

●DTY-HA01

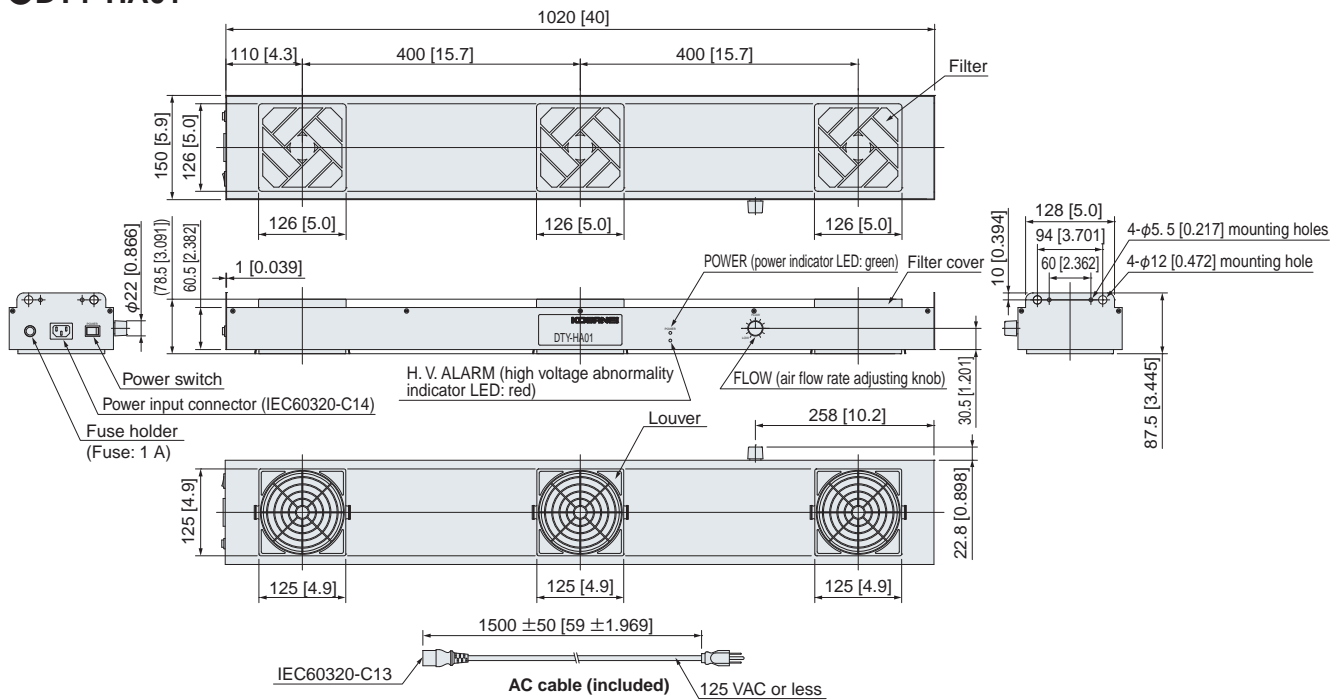

Note: The AC cable that is included is for 100 VAC (125 VAC or less).
Provide a suitable power cord separately if you are using over 125 VAC.

Handling instructions and precautions (wide area fan type, overhead fan type)

Installing

1. When installing, ensure enough space so that the inlet does not get blocked.
2. Be careful of water and oil contamination, high temperatures, and high humidity. Especially avoid locations on which condensation forms.

Cautions during use

1. Be sure to remove the AC adaptor (AC cable for overhead fan types) before doing inspections, cleaning, or maintenance.
2. Failure to do so may result a high voltage being applied to the discharge needle and causing electric shock. Never touch the discharge needle when the power is on.
3. The tip of the discharge needle is sharp, so be careful when cleaning and when removing the discharge needle unit. Failure to do so may result in injury. Also, be very careful so that the discharge needle does not bend or break. If it does, performance may begin to deteriorate.
4. Do not disassemble the discharge needle unit. The tip of the discharge needle is sharp, so doing so may result in injury.
5. Maintenance is an extremely important aspect for maintaining performance. Do periodic maintenance because performance may deteriorate when the usage environment is poor (such as an atmosphere with high humidity) or when the discharge needle is not clean. For how to do maintenance, see the instruction manual attached to the product.
6. The operating life of the discharge needle varies depending on the condition of the usage environment. Maintenance is required because loss of performance may occur when the usage environment is poor (such as an atmosphere with high humidity) or when the discharge needle is not clean.
7. After the power is turned on, it takes about five seconds for the fan's rotation to stabilize. To obtain stable performance in eliminating static charge, avoid using the product in this transitional state.

***Read the safety precautions and common precautions on the ionizer general catalog homepage before using this produce.**



KOGANEI CORPORATION

OVERSEAS DEPARTMENT
3-11-28, Midori-cho, Koganei City, Tokyo 184-8533, Japan
Tel: 81-42-383-7271 Fax: 81-42-383-7276

KOGANEI ASIA PTE. LTD.
69 Ubi Road 1, #05-18 Oxley Bizhub,
Singapore 408731
Tel: 65-6293-4512 Fax: 65-6293-4513

KOGANEI (THAILAND) CO., LTD.
3300/90, Tower B, Elephant Tower, 16th Fl., Phaholyothin Road,
Chomphon, Chatuchak, Bangkok 10900, Thailand
Tel: 66-2-937-4250 Fax: 66-2-937-4254

Koganei International America, Inc.
39300 Civic Center Drive, Suite 280
Fremont, California 94538
Tel: 510-744-1626 Fax: 510-744-1676

URL <http://www.koganei.co.jp>

● Note that improvements may result in unannounced changes to the specifications and appearances described here.

12/16 50 ABAB © KOGANEI CORP. PRINTED IN JAPAN